



# E2100

## FREQUENCY INVERTER

0.2kW-400kW/0.3HP-540HP

cUL/UL Certification 0.4kW-185kW/0.5HP-245HP



[www.euradrives.net](http://www.euradrives.net)

[www.euradrives.com](http://www.euradrives.com)

### AN ENVIRONMENT FRIENDLY VFD:

Combining Renowned Energy Savings & IE2 Efficiency of Our Drives, With the Unique Random Carrier Wave Management System. For A Green Solution & The Lowest Audible AC Motor Noise in The Industry.



# E2100

0.2 kW - 400 kW / 0.3HP - 540HP

## FREQUENCY INVERTER

### HIGHLIGHTS

- Advanced motor control using Hybrid DSP technology. Control Mode selections include: PMM (Surface & Internal Mounted Magnets); SYNCHRONOUS RELUCTANCE (Software Option); CLOSED LOOP / FOUR QUADRANT; SVC/FOC; Classic V/Hz
- Intelligent AUTOTUNING functions for easy setup
- Compact size to save panel space, modular, rugged construction, built for a worldwide market
- Flexible inverter control, high resolution analog inputs, free mapping for all I/O channels
- MODBUS-RS485 ready. CANbus for master/slave mode, Ethernet, Ethernet IP, BACnet available
- Universal parameter set for various industrial applications, integrated PID controller routines, Auto-Randomized carrier frequency (For Low Audible Motor Noise), Auto V/Hz curve for torque and efficiency control.
- Eura DV software for inverter control, programming and troubleshooting
- Parameter duplication stick including USB to RS-485 converter
- Standard & optional built-in brake IGBT (see DB Options Code Notes below).
- C3 class filter is standard (meets & exceeds EMC standards EN55011 class A group 2 or IEC/EN 61800-3 category C3 for EMI & RFI filtration)
- EuraDV™ software (free online at our "Downloads" page) for inverter control, programming, diagnostics, and troubleshooting. The software connects the VFD to a PC using the EURA CopyStick™ (Parameter duplication stick and USB to RS-485 converter).
- Approved and certified for worldwide standards, by independent organizations



## E2100 Model Code & Options Code Designations

### Mode Code

**E2100 – 0007 S2**

S1:1-Phase 110~120VAC  
 S2:1-Phase 220~240VAC  
 T2:3-Phase 220~240VAC  
 T3:3-Phase 380~480VAC  
 T5:3-Phase 575~600VAC

Motor power

Mark	0007	0015	0022	.....
Motor power(kW)	0.75	1.5	2.2	.....

Product series

### Options Code

**E2 U5 F15AF03 B1 R3**

Filter	R3	C3 level filter
Braking type	B1	Built-in Braking Chopper
Keypad	AF03	AF English no potentiometer LED keypad
Communication	F15	Modbus+CAN
Certificate	U5	UL+cUL+CE
	U9	UL+cUL+CE+STO
Structure code	E2	E2 structure

#### Remarks:

- For 3-phase 460V, 30kw and below - Braking chopper is standard.
  - For 3-phase 230V, 1.5kW and below, 4.0kW~11kW - Braking chopper is standard.
  - For 3-phase 575V, 18.5kW and below - Braking chopper is standard.
- The built-in braking chopper of other models is optional.

## Communication:

Structure code	Communication code	Contents
E1	F2	Modbus
E2 structure and above	F15	Modbus+CAN

## Remote Keypad Model:

Keypad	
A603	1-line LED keypad (IP20 level)
A604	1-line LED keypad with potentiometer (IP20 level)
AD02	4-line LCD keypad (IP66 level)

## Certificate:

Certificate Code	Contents	Inverter power
U1	CE	≤400 kW
U5	UL+cUL+CE	≤185 kW
U9	UL+cUL+CE+STO	≤185 kW

# Technical Product Data

	Items	Contents
Input	Rated Voltage Range	3-phase 380-480V (+10%, -15%) note 1 3-phase 220V~240V ±15% 3-phase 525V-600V(+10%, -15%) 1-phase 110-120V ±15% 1-phase 220-240V ±15%
	Rated Frequency	50/60Hz
Output	Rated Voltage Range	3-phase 0-INPUT (V)
	Frequency Range	0.50~590.0Hz (In SVC control mode, the max frequency should be lower than 500Hz.)
Control Mode	Carrier Frequency	800~16000Hz; Fixed carrier-wave and random carrier-wave can be selected by F159
	Input Frequency Resolution	Digital setting: 0.01Hz, analog setting: max frequency X 0.1%
	Control Mode	PMM (Surface & Internal Mounted Magnets) SYNCHRONOUS RELUCTANCE (Software Option) CLOSED LOOP / FOUR QUADRANT SVC/FOC Classic V/Hz
	Start Torque	0.5Hz/150% (SVC) 0Hz/180% (VC), 5% of rated speed/100% of rated torque (PMSM SVC)
	Speed-Control Scope	1:100 (SVC), 1:1000 (CLVC), 1:20 (in PMSM SVC)
	Steady Speed Precision	±0.5%~(SVC), ±0.02%(CLVC)
	Torque Control Precision	±5%
	Overload Capacity	150% rated current, 60 seconds. Adjustable as required.
	Torque Elevating	Auto torque promotion, Manual Torque Promotion includes 1-20 curves.
	V/F Curve	3 kinds of modes: Constant / Linear, Variable / Squared, and under-defined V/F curve
	Startup Mode	Directed Rotation Startup, flying startup (V/F control), (Also stops wrong direction with DC Braking)
	DC Braking	DC braking frequency: 0.20-50.00 Hz, braking time: 0.00~30.00s
	Jogging Control	Jogging frequency range: min frequency~max frequency, jogging acceleration/deceleration time: 0.1~3000s
Auto Circulating Run Assignments	Automatically Cycling Through: ·Lead Pump Selection (Runtime-Sharing) ·Up To 15-Stage Multi-Speeds ·Staging Roles	
Built-in PID	Easy closed-loop process control for Flow, Pressure, Temperature, Sleep Mode, Etc.	
Auto Voltage Regulation (AVR)	When the source voltage changes, the modulation rate can be adjusted automatically, so the output voltage is unchanged.	
Operation Function	Speed Reference(s)	Selectable Combinations or Single Reference for Speed Via: ·Potentiometer ·External Analog Signal (0~5V, 0~10V, 0~20ma) ·Keypad (Terminal)▲/▼ Keys ·External Control Logic ·Auto Circulating Run Assignments
	Start/Stop Control Source	Selectable Combinations or Single Reference for Start/Stop Via: ·D.I. Control Terminals ·Keypad Control ·Fieldbus Communication Control
	Frequency Reference Sources	Frequency sources can be combined: given digit, given analog voltage, given analog current and given MODBUS
	Accessorial Frequency Source	7 kinds of accessorial frequency refer to F207

Items	Contents	
Standard Features	Built-in EMI filter, built-in braking unit (when not included as standard), Keypad with Potentiometer, Relay & I/O expansion cards, Fieldbus cards, and more.	
Protection Function	Input phase loss, Output phase loss, input under-voltage, DC over-voltage, over-current, inverter over-load, motor over-load, current stall, drive over-heat, under-load, pressure control, analog line disconnected, PG line disconnection, keypad disconnection, STO and STO1.	
Display	Keypad can display: output frequency, speed (rpm), output current, output voltage, linear-velocity, fault type, System & Operation parameters. LED indication: RUN = Operating Status, FWD = Forward direction is active, DGT = programming digits are selectable, FRQ = Frequency is display on screen.	
Environment Conditions	Equipment Location	In an indoor location, Prevent exposure from direct sunlight, Free from dust, caustic gases, flammable gases, steam or the salt-contented, etc
	Environment Temperature	-10 ℃ ~ +50 ℃
	Environment Humidity	Below 90%
	Vibration Strength	Below 0.5g
Altitude Above Sea Level	1000m or below	
Protection Level	IP20 (Panel Chassis); IP21 (NEMA 1 ) Kit optional for stand-alone Wall-Mount	
Applicable Motor	0.2 ~ 400kW	

Note 1: Under different voltage levels, user should connect jumper on the pin board, the model of pin board is E2F3UZ00.

1) When input voltage is 380~420VAC, please connect CN2 to CN3 (380V Jumper).

2) When input voltage is 420~480VAC, please connect CN4 to CN5 (480V Jumper). The jumper detail applies only to drive size >132kw.

The default system is 380~420VAC, if some operation is needed, please power off inverter and contact profession engineer.

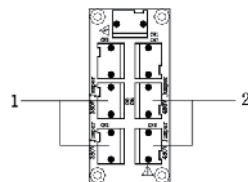

## Functions of Control Terminals

Terminal	Type	Description	Function	
DO1	Output Signal	Multifunctional output terminal 1	When the token function is valid, the value between this terminal and CM is 0V; when the inverter is stopped, the value is 24V. When DO1 is as high-frequency output terminal, the max output frequency is 100KHz and please do not connect to intermediate relay.	
DO2 <sup>Note 1</sup>		Multifunctional output terminal 2		
TA		Relay contact		TC is a common point, TB-TC are normally closed contacts, TA-TC are normally open contacts. The contact capacity is 10A/125VAC, NO/NC 3A 250VAC/30VDC.
TB				
TC				
AO1	Output Signal	Voltage/current output	Analogue output AO1 can be connected to either a frequency meter, speedometer or ammeter externally; The negative of the meter would then be connected with VFD Control Terminal GND. See F423 ~ F426 for details. Analogue Output can also be used as speed reference for a slave VFD.	
AO2		Current output	Analogue output AO2 can be connected with ammeter externally, the negative of the meter would then be connected with VFD Control Terminal GND. See F427 ~ F430 for details. Analogue Output can also be used as speed reference for a slave VFD.	
10V	Analog Power Supply	Self-contained power supply	Internal 10V inverter power supply provides power to the inverter. When used externally, it can only be used as the power supply for voltage control signal, with current restricted below 20mA.	
A1 <sup>Note 2</sup>	Input Signal	Voltage analog input port	When analog speed control is adopted, the voltage or current signal is input through this terminal. The range of voltage input is 0~5V or 0~10V or -10V-10V, and the current input is 0~20mA, the input resistor is 50Ohm, and grounding: GND. If the input is 4~20mA, it can be realized by setting F406=2. The voltage or current signal can be chosen by coding switch. See table 5-2, 5-3 for details, the default setting of A11 is 0~10V, and the default setting of A12 is 0~20mA.	
A12		Voltage / current analog input port		
GND		Self-contained power supply ground	Ground terminal of external control signal (voltage control signal or current source control signal) is also the ground of 10V power supply of this inverter.	

# Functions of Control Terminals

Terminal	Type	Description	Function
24V	Power Supply	Control power supply	Power: 24±1.5V, grounding is CM; current is restricted below 200mA for external use.
DI1	Digital Input Control Terminal	Jogging terminal	When this terminal is valid, the inverter will have jogging running. The jogging function of this terminal is valid under both at stopped and running status. This terminal can also be used as high-speed pulse input port. The max frequency is 100KHz.
DI2		External emergency stop	When this terminal is valid, "ESP" malfunction signal will be displayed.
DI3		"FWD" Terminal	When this terminal is valid, inverter will run forward.
DI4		"REV" Terminal	When this terminal is valid, inverter will run reversely.
DI5		Reset terminal	Make this terminal valid under fault status to reset the inverter.
DI6		Free-stop	Make this terminal valid during running can realize free stop.
DI7 <sup>Note 1</sup>		Running terminal	When this terminal is in the valid state, inverter will run by the acceleration time.
DI8 <sup>Note 1</sup>		Stop terminal	Make this terminal valid during running can realize stop by the deceleration time.
CM	Common Port	Grounding of control power supply	Grounding of 24V power supply and other control signals.
GND		Grounding of differential signal	Grounding of differential signal
5V	485 Communication Terminals	Power of differential	Power- differential signal
A+		Positive polarity of differential signal	Standard: TIA/EIA-485(RS-485) Communication protocol: Modbus
B-		Negative polarity of differential signal	Communication rate: 1200/2400/4800/9600/19200/38400/57600bps

The functions of input terminals shall be defined per manufacturer's value. Other functions can also be defined by changing function codes

TA	TB	TC	DO1	DO2	24V	CM	DI1	DI2	DI3	DI4	DI5	DI6	DI7	DI8	10V	AI1	AI2	GND	AO1	AO2
GND	5V	A+	B-																	

Note:

1. T3 30kW and below and T2 2.2kw and below inverters have no DO2, DI7 and DI8 control terminals.
2. AI1 terminal of T3 30kW and below and T2 2.2kw and below inverters can only accept voltage signal, the default voltage is 0~10V.
3. 3-Phase 575V 18.5kW and below inverters have no DO2, DI7 and DI8 control terminals.
4. 3-Phase 575V 18.5kw and below inverters can only accept voltage signal, the default voltage is 0-10V.

# Product List

Model	Applicable Motor (kW/HP)	Rated Output Current	Structure Code	External Dimension [A×B(B1)×H] mm <sup>NOTE1</sup>	Mounting Size (W×L) mm	Mounting Bolt	Cooling Mode	Remarks
E2100-0004S1	0.4/0.5	2.5	E2	106×150(157)×180(195)	94×170	M4	Self-Cooling	1-phase 110V Industrial Polycarbonate Housing
E2100-0007S1	0.75/1	4.5	E2	106×150(157)×180(195)	94×170	M4	Air-Cooling	
E2100-0015S1	1.5/2	7.0	E4	142×152(159)×235(248)	126×225	M5	Air-Cooling	
E2100-0022S1	2.2/3	10.0	E4	142×152(159)×235(248)	126×225	M5	Air-Cooling	
E2100-0002S2	0.2/0.3	1.5	E1	80×135(142)×138(153)	70×128	M4	Air- Cooling	1-phase 230V Industrial Polycarbonate Housing
E2100-0004S2	0.4/0.5	2.5	E1	80×135(142)×138(153)	70×128	M4	Air- Cooling	
E2100-0007S2	0.75/1	4.5	E1	80×135(142)×138(153)	70×128	M4	Air- Cooling	
E2100-0015S2	1.5/2	7.0	E1	80×135(142)×138(153)	70×128	M4	Air- Cooling	
E2100-0022S2	2.2/3	10.0	E2	106×150(157)×180(195)	94×170	M4	Air- Cooling	

# Product List

Model	Applicable Motor (kW/HP)	Rated Output Current	Structure Code	External Dimension [A×B(B1)×H] mm <sup>NOTE1</sup>	Mounting Size (W×L) mm	Mounting Bolt	Cooling Mode	Remarks
E2100-0002T2	0.2/0.3	1.5	E1	80×135(142)×138(153)	70×128	M4	Air- Cooling	3-phase 230V Industrial Polycarbonate Housing
E2100-0004T2	0.4/0.5	2.5	E1	80×135(142)×138(153)	70×128	M4	Air- Cooling	
E2100-0007T2	0.75/1	4.5	E1	80×135(142)×138(153)	70×128	M4	Air- Cooling	
E2100-0015T2	1.5/2	7	E1	80×135(142)×138(153)	70×128	M4	Air- Cooling	
E2100-0022T2	2.2/3	10	E2	106×150(157)×180(195)	94×170	M4	Air- Cooling	
E2100-0030T2	3.0/4	12	E2	106×150(157)×180(195)	94×170	M4	Air- Cooling	
E2100-0040T2	4.0/5.5	17	E4	142×152(159)×235(248)	126×225	M5	Air- Cooling	
E2100-0055T2	5.5/7.5	21	E5	161×170(177)×265(280)	146×225	M5	Air- Cooling	
E2100-0075T2	7.5/10	30	E6	210×196(203)×340(358)	194×330	M5	Air- Cooling	
E2100-0110T2	11/15	40	E6	210×196(203)×340(358)	194×330	M5	Air- Cooling	
E2100-0007T3	0.75/1	2.0	E1	80×135(142)×138(153)	70×128	M4	Air- Cooling	3-phase 460V Industrial Polycarbonate Housing
E2100-0015T3	1.5/2	4.0	E1	80×135(142)×138(153)	70×128	M4	Air- Cooling	
E2100-0022T3	2.2/3	6.5	E2	106×150(157)×180(195)	94×170	M4	Air- Cooling	
E2100-0030T3	3.0/4	7.0	E2	106×150(157)×180(195)	94×170	M4	Air- Cooling	
E2100-0040T3	4.0/5.5	9.0	E2	106×150(157)×180(195)	94×170	M4	Air- Cooling	
E2100-0055T3	5.5/7.5	12.0	E4	142×152(159)×235(248)	126×225	M5	Air- Cooling	
E2100-0075T3	7.5/10	17.0	E4	142×152(159)×235(248)	126×225	M5	Air- Cooling	
E2100-0110T3	11/15	23.0	E5	161×170(177)×265(280)	146×225	M5	Air- Cooling	
E2100-0150T3	15/20	32.0	E5	161×170(177)×265(280)	146×225	M5	Air- Cooling	
E2100-0185T3	18.5/25	38.0	E6	210×196(203)×340(358)	194×330	M5	Air- Cooling	
E2100-0220T3	22/30	44.0	E6	210×196(203)×340(358)	194×330	M5	Air- Cooling	
E2100-0300T3	30/40	60	E6	210×196(203)×340(358)	194×330	M5	Air- Cooling	
E2100-0370T3	37/50	75	E7	265×235(242)×435(465)	235×412	M6	Air- Cooling	
E2100-0450T3	45/60	90	E7	265×235(242)×435(465)	235×412	M6	Air- Cooling	
E2100-0550T3	55/75	110	C51	360×265×630	320×605	M8	Air- Cooling	3-phase 460V metal housing
E2100-0750T3	75/100	150	C51	360×265×630	320×605	M8	Air- Cooling	
E2100-0900T3	90/120	180	C61	410×300×765	370×740	M10	Air- Cooling	
E2100-1100T3	110/150	220	C61	410×300×765	370×740	M10	Air- Cooling	
E2100-1320T3	132/180	265	C61	410×300×765	370×740	M10	Air- Cooling	
E2100-1600T3	160/220	320	C7	516×326×765	360×740	M10	Air- Cooling	
E2100-1850T3	185/245	360	C8	560×342×910	90×882	M10	Air- Cooling	
E2100-0007T5	0.75/1	1.7	E2	106×150(157)×180(195)	94×170	M4	Air- Cooling	3-phase 600V Industrial Polycarbonate Housing
E2100-0015T5	1.5/2	3.5	E2	106×150(157)×180(195)	94×170	M4	Air- Cooling	
E2100-0022T5	2.2/3	4.5	E2	106×150(157)×180(195)	94×170	M4	Air- Cooling	
E2100-0030T5	3.0/4	5.5	E4	142×150(157)×180(195)	126×225	M5	Air- Cooling	
E2100-0040T5	4.0/5.5	7.5	E4	142×150(157)×180(195)	126×225	M5	Air- Cooling	
E2100-0055T5	5.5/7.5	10.0	E4	142×150(157)×180(195)	126×225	M5	Air- Cooling	
E2100-0075T5	7.5/10	13.5	E4	142×150(157)×180(195)	126×225	M5	Air- Cooling	
E2100-0110T5	11/15	19.0	E6	210×196(203)×340(358)	194×330	M5	Air- Cooling	
E2100-0150T5	15/20	23.0	E6	210×196(203)×340(358)	194×330	M5	Air- Cooling	
E2100-0185T5	18.5/25	27.0	E6	210×196(203)×340(358)	194×330	M5	Air- Cooling	
E2100-0220T5	22/30	34.0	C4A	315×250×476	274×460	M6	Air- Cooling	3-phase 600V metal housing
E2100-0300T5	30/40	41.0	C4A	315×250×476	274×460	M6	Air- Cooling	
E2100-0370T5	37/50	52.0	C4A	315×250×476	274×460	M6	Air- Cooling	
E2100-0450T5	45/60	62.0	C5	360×265×555	320×530	M8	Air- Cooling	
E2100-0550T5	55/75	80.0	C5	360×265×555	320×530	M8	Air- Cooling	

Note 1: B1 Dimension is with Potentiometer Keypad Option

H1 Dimension is with Ground Plate Option for Cables

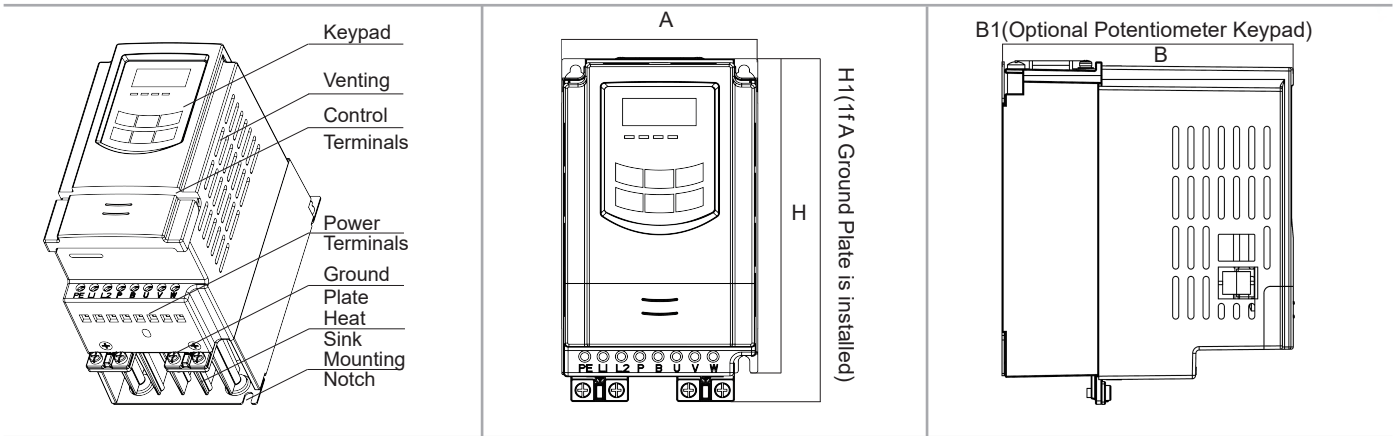

# Wiring Diagram

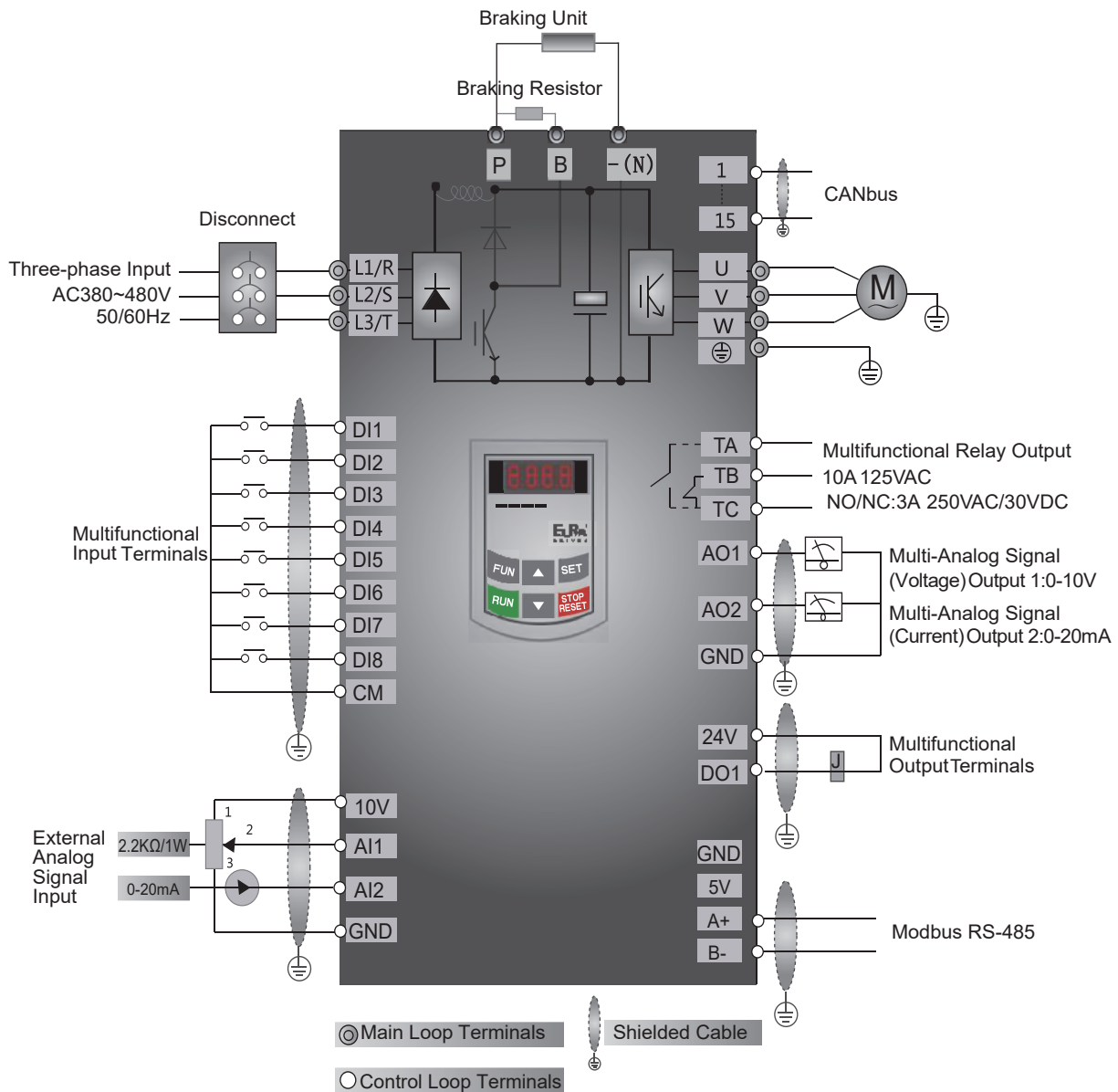

Basic Wiring Diagram for Three-phase AC Drives(NPN type)

# Manufacturing Power Inverter & Automation Products since 1992

## **EURA DRIVES CANADA LTD**

328 Consumers Road  
North York, Ontario M2J 1P8  
Canada

Tel: +1 647 512 7958  
[contact@euradrives.net](mailto:contact@euradrives.net)  
[www.euradrives.net](http://www.euradrives.net)

