



This drive is a speed controller for shunt wound or permanent magnet motors. It utilizes speed feedback from the armature voltage, or from a shaft mounted tacho-generator. It incorporates an accurate current control loop to protect the drive and motor.

POWER RATING

DRM050 0.50 HP at 180 VDC, 0.25 HP at 90 VDC
 DRM100 1.00 HP at 180 VDC, 0.50 HP at 90 VDC
 DRM200 2.00 HP at 180 VDC, 1.00 HP at 90 VDC

MAXIMUM OUTPUT

Armature: 200 Volts DC. **Field:** 0.9 x AC supply.
 Models DRM 050/ 100 /200 --- 3.4/ 6.8/ 12.2 Amps.

AC INPUT

110V AC or 240V AC +/-10%, 50–60 Hz.

SPEED RANGE

Speed range 0–100%. (motor dependant)
 Load Regulation typically 0.2% tach, 2% Arm Volts.

USER ADJUSTMENTS

Presets accessible under lift up cover.
 Clockwise rotation for linear increase in parameter

Maximum Speed
 Minimum Speed
 Ramp
 IR compensation
 Current

50 to 200V (armature volts or tach feedback volts)
 0 to 30% of maximum speed
 1 to 20 seconds up ramp rate
 0 to 25%
 0 to 100% current limit.

EXTERNAL CONTROLS

Speed setpoint from **external 10K Ohms pot.**
 External RUN contact for electronic STOP/START
 There is a pot kit including graduated dial and knob.

CONTROL ACTION

Speed loop: Full P+I armature voltage feedback.
 Current loop: Full P+I current shunt feedback.

INSTALLATION

Use correctly rated cable minimum 600V AC,
 1.5 times armature current.

FUSES

12.5A fuse 6 X 32
 Fuseholder 6 X 32
 DIN rail clip for fuseholder

WARNING The drive can only be protected by fitting an external semi-conductor fuse with an I²t rating below 150 A²s.

CONTROL SIGNALS

All control inputs to the drive are **NON-ISOLATED**.

Do not connect any of the terminals to earth or other non-isolated equipment.

A common cause of damage is accidental earthing of the external pot or RUN contact wiring. DO NOT TOUCH ANY CONNECTIONS TO THE UNIT.

MECHANICAL

The unit is designed to clip onto a DIN rail. Avoid vibration and ambient temperatures outside –10 and +40C. Protect the unit from pollutants. Ensure there is an adequate supply of clean cool air to allow ventilation of the unit.

MOTOR CONDITION

Foot mounted motors must be level and secure. Protect motors from ingress of foreign matter during installation. Ensure accurate alignment of motor shaft with couplings.

Do not hammer pulleys or couplings onto the motor shaft.

Before running motor complete the following check list.

- 1) Correct insulation between all motor windings and earth with all drive cables disconnected.
- 2) Check inside connection box for foreign objects, damaged terminals etc.
- 3) Check that brushes are in good condition, correctly seated and free to move in brush boxes.
- 4) Check correct action of brush springs.
- 5) Motor vents must be freed of any obstruction or protective covers prior to running.
- 6) **WARNING** for reversing systems. To prevent damage do not transpose the armature connections until the motor has stopped rotating.

AC POWER SUPPLY

To avoid damage, ensure the supply selection jumper on the drive matches the incoming supply. 110V or 240V AC.

PRESET POT SETTINGS

Set the CURRENT preset to approximately match the motor armature rating. Fully clockwise is 100% drive rating. ('075' 3.4A, '100' 6.8A, '200' 12.2A).

Fully anticlockwise is 0%. E. g. for a 340 unit a midway setting is 50% ie 1.7A.

More accurate setting requires a suitable current meter in series with the armature.

Set all the other presets anticlockwise to start off with.

The safest strategy for initial commissioning is in armature voltage feedback mode described as follows. Set switch 1 ON for armature voltage feedback (AVF) and switch 2 OFF for 50V max feedback. For systems utilising tach feedback, remove the terminal 6 tach connection.

POWER ON

Check that the ON lamp lights. Increase the external speed pot slowly to maximum. The motor should slowly ramp up to around 40V on the motor armature. If the system is to rely on armature voltage feedback you can now set the correct armature voltage and hence speed by using switch 2 (ON for speed X 2) and the MAX SPEED preset (Clockwise to increase speed).

RAMP and MIN SPEED

The up RAMP rate can now be set between 1 and 20 seconds. And the MIN SPEED adjusted up to 30%.

IR COMP Speed droop on heavy loads may occur where armature voltage feedback is used. This is compensated for by clockwise rotation of IR COMP. Excessive rotation may lead to instability. **IR COMP is not used with tach feedback, leave preset anticlockwise.**

TACH FEEDBACK With tach feedback it is necessary for the polarity to be negative on terminal 6 with respect to terminal 4, and AVF switch 1 OFF (up). Calculate the maximum feedback voltage from the tach and adjust switch 2 and MAX SPEED to give the correct speed. (With switch 2 OFF (up) MAX SPEED range = 40 to 100V. For switch 2 ON (down) MAX SPEED range = 90 to 200V).

TERMINAL LISTING **WARNING. All terminals are at high potential. DO NOT TOUCH the terminals or any connected conductor**

- 1 +10V output. 2mA max. (Use a 10K Ohm pot for external speed reference).
- 2 MIN SPEED. (Bottom end of external pot. 5K Ohms preset to common).
- 3 SPEED INPUT. 0 to +10V speed input from pot wiper. 39K internal pull down.
- 4 COMMON.
- 5 RUN. Internal 12K pull up to +12V. Open to reset, close to COMMON to run. **WARNING. RUN is an electronic inhibit function. The field remains energised, and all power terminals 'live'. RUN must not be relied on during hazardous operations**
- 6 TACH input. The tach feedback must be negative with respect to COMMON.
- A+ Motor armature +
- A- Motor armature -
- F- Motor Field – (No connection required for permanent magnet motors).
- F+ Motor Field +(For half wave field volts $0.45 \times AC$, connect field to F- and N).
- N AC supply
- L AC supply

ALARM Models 100 and 200 use an internal fan for cooling. The ALARM lamp will come ON and the drive will electronically shut down if the internal fan fails. The field will remain energised, hence if the machine is to be left unattended for long periods it may cause the field to overheat. There is a pair of solder pads adjacent to Terminal 6. If they are linked then the ALARM is inhibited. The unit may be run at currents below 3 Amps without a fan.

JOGGING For frequent stopping or jogging it is recommended to use the RUN input. If you must use the mains contactor then connect a spare Normally Open contact on the contactor in series with the RUN input.

AUXILIARY INPUT In armature voltage feedback the tach input terminal 6 may be used as an auxiliary fast +/- speed trim. (approx 5-10%)

MECHANICAL DETAILS The product is enclosed in a stylish DIN rail mounted enclosure with plug in screw terminal connections.

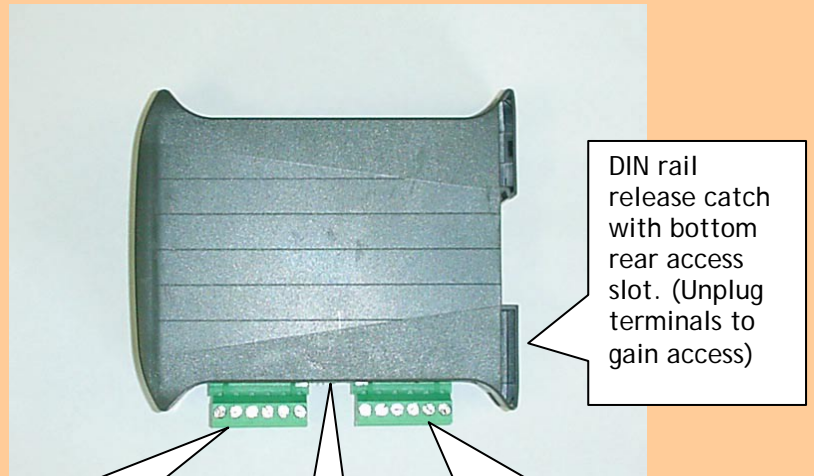
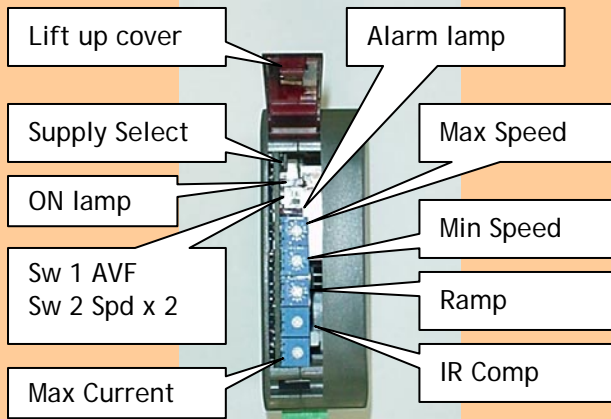

Model	Height	Width	Depth
050	4.1"	1.4"	4.7"
100	4.1"	1.8"	4.7"
200	4.1"	1.8"	4.7"

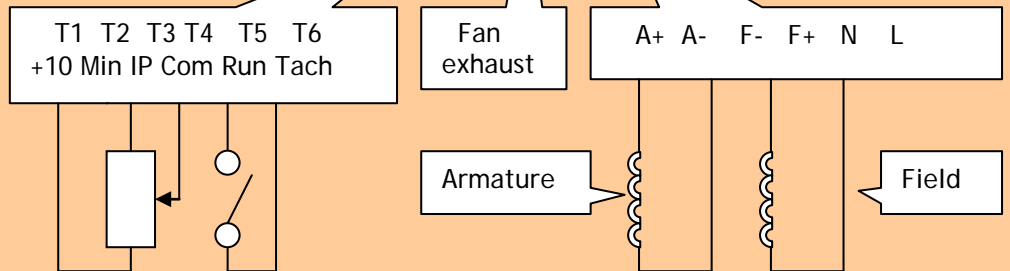

EMC WIRING GUIDE

If the unit is to be used in the domestic environment then a supply filter is recommended.

WARNINGS

Health and safety at work. Electrical devices constitute a safety hazard. It is the responsibility of the user to ensure compliance with any acts or bylaws in force. Only skilled persons should install this equipment. Polyspede Electronics Corp. does not accept any liability whatsoever for the installation, fitness for purpose or application of its products. It is the users responsibility to ensure the unit is correctly used and installed.

APPROVALS

This apparatus complies with the protection requirements of the relevant EU directives. The unit is listed.

