

**hi**RUN **N700**

# Hundai Inverter

| The Controlling Solution of Powerful Inverter brand |





## Hundai's Technology For the Best

High Performance Inverter for Efficient Business Design

the best future with  **RUN**  **700** Series





## **Hi**RUN **N**700 Series with Powerful Control solution

| Excellent Applicability to various Loads |

| Easy Maintenance & Simple Repair |

| High Reliability & Durability |

| Compliance with RoHS |

| Low Motor Noise |

For the highest quality ,  
For the maximum customer satisfaction



HYUNDAI inverter N700 series can be applied to various loads that are required for precision and powerful control thanks to its excellent durability, speed and torque response.

Strong torque restriction function protects the machines from external torque changes.

N700 series is compliant with RoHS directive and international safety standards such as CE, UL and cUL.



### Model Name Indication

#### Model name indication

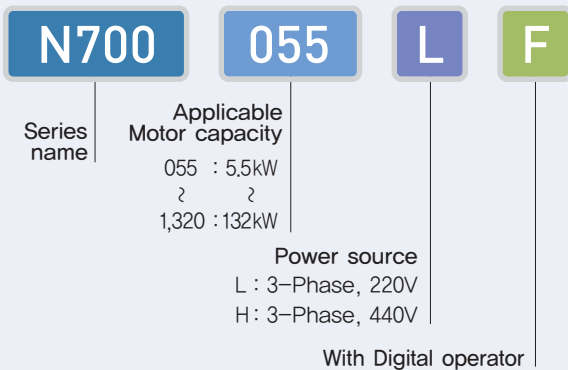

#### Model configuration

Applicable Motor Capacity (kW)	3-Phase, 220V		3-Phase, 440V	
	LF	HF	LF	HF
5.5	N700-055LF	N700-055HF		
7.5	N700-075LF	N700-075HF		
11	N700-110LF	N700-110HF		
15	N700-150LF	N700-150HF		
18.5	N700-185LF	N700-185HF		
22	N700-220LF	N700-220HF		
30	N700-300LF	N700-300HF		
37	N700-370LF	N700-370HF		
45	N700-450LF	N700-450HF		
55	N700-550LF	N700-550HF		
75		N700-750HF		
90		N700-900HF		
110		N700-1100HF		
132		N700-1320HF		



## Contents

06 | Features / 12 | Standard / 14 | Dimension

16 | Operation / 17 | Operation setting / 18 | Function list

27 | Terminals / 29 | Connecting diagram / 30 | Connecting to PLC

31 | Protective functions / 32 | Wiring and options / 38 | For correct operation

## :: Improved control performance

### Advanced sensorless vector control at ultra low speed

- Excellent control performance with all machines thanks to the improvement of torque characteristic at low speed.
- Sensorless vector control : 200% or greater at 0.5Hz
- Sensored vector control : 150% or greater at 0Hz

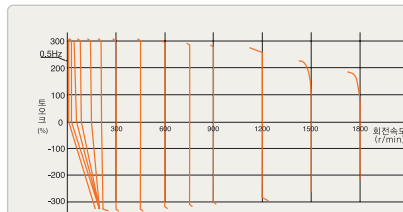

N700-055LF와 현대 범용 3상모터, 5.5kW, 4극 조합시  
EX) <기저주파수 60Hz>  
(주) 토크 특성은 기종에 따라 차이가 있을 수 있습니다.

### Excellent response speeds and torque control performance

- Improvement of the torque response characteristic minimizes the speed deviation by change of a load. (Quick response to a sudden load change is realized.)
- Strong torque restriction function (adjustable 0~200%) can protect a machine from external unexpected load change.
- Minimize an response speed regarding a port order.

Apply rated torque

After torque removal

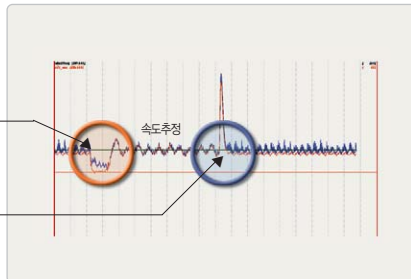

▶ 향상된 토크 응답 특성

Speed control for torque control

Apply torque

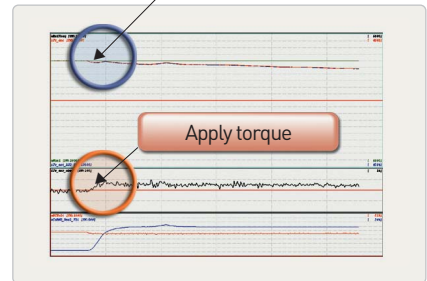

▶ 토크 제한 기능을 통한 기계보호

### Improvement of reduced torque characteristic

- Reduced torque characteristic (VP2.0 power) is added for softer motor operation.
- Optimization for energy saving by the characteristic of loads is achieved.

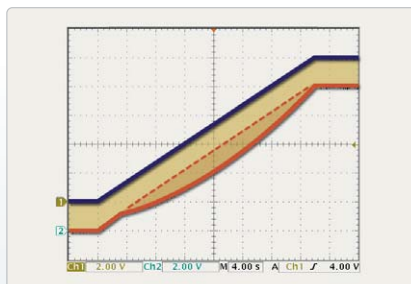

▶ Energy-saving by VP1.7 power

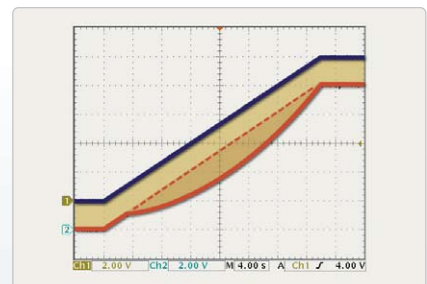

▶ Energy-saving by VP2.0 power

### Expansion of multi-speed control function

- Besides the basic accel.-decel. time, maximum 7 individual accel.-decel. time settings are available. With terminal input only, you can change the accel-deceleration time, which leads to the precise control.
- Three step accel.-decel. time setting is possible.

### Stable and strong torque operation

- As users may select either speed control or torque control at their convenience, they can apply N700 inverters to various applications (Vector Control).

### Expansion in the weak field driving scope

- The weak field range where the maximum torque operation can be made is extended to 320Hz.

### Advanced On Line, Off Line Auto-tuning

- On line and off line auto-tuning for sensorless control
- Even in case of off line auto-tuning, the characteristic of the torque and speed control is excellent. (Regardless of the load conditions, auto-tuning can be performed)
- In case of on line auto-tuning, precise operation can be realized through the automatic compensation for motor constant method even when the motor's temperature changes.

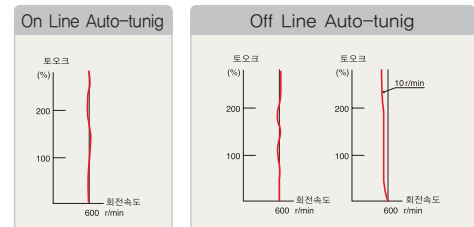

### Improved DC brake function

- Improved brake characteristic at stop command by upgrading the DC brake function.

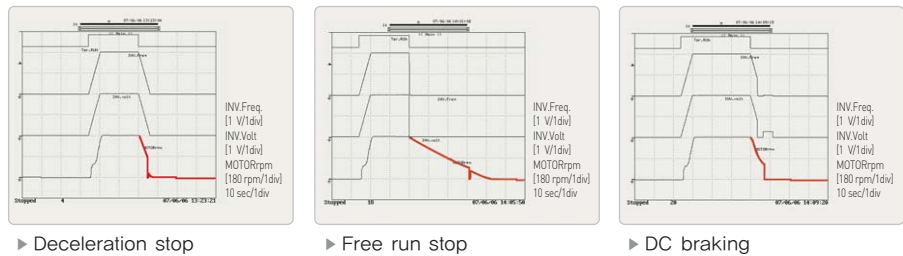

### External brake control function for elevators

- By using the external brake for the elevator application, safe and detailed control on all the variables is realized. The operating speed can be changed in accordance with the duty of the load.

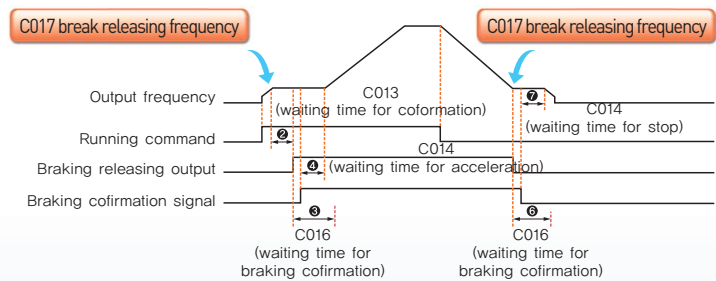

### High quality voltage and current

- Even if the incoming voltage fluctuates, the AVR function keeps the output voltage to the motor constant.
- The 'Trip Avoidance Function' to control the over-current and over-voltage help supply the high quality of power source to the motor.

### Automatic speed search even after unexpected interruption of input power

- The inverter and motor can be safely restarted or protected by FRS and RETRY function.
- Variable speed search restart mode can be selected for safe driving.
- By using the frequency matching restart and speed search function, the inverter can match the motor's speed after unexpected power failure.

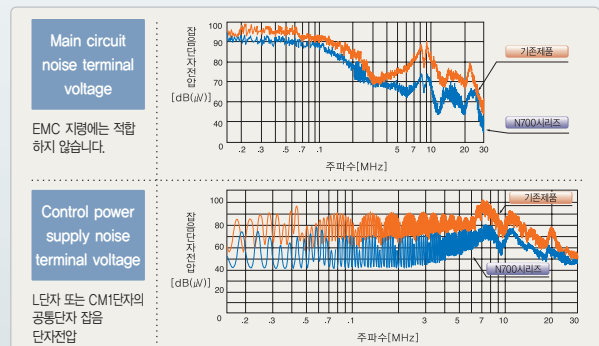

[ 인버터에서 발생하는 노이즈 및 누설전류 감소 효과 ]

### IGBT temperature check

- The temperature of IGBT(core part of inverter) is checked and displayed.

## :: Easy Operation and Maintenance

### Various inverter display functions

- All the data of the inverter are displayed on the monitor.
  - The trip data of each phase is displayed in case of input phase loss and output short
  - Temperature on the IGBT
  - Others (In-Out voltage, current, frequency, DC voltage, input power, RPM of motor, rotation direction, frequency change, PID Feedback, accumulated operating time (hour, minute), total power up time (hour, minute), error and trip count display)

### RUN(0,1,2) relay control terminal added

- Run output terminals (RN0,1,2) are added for user's convenience

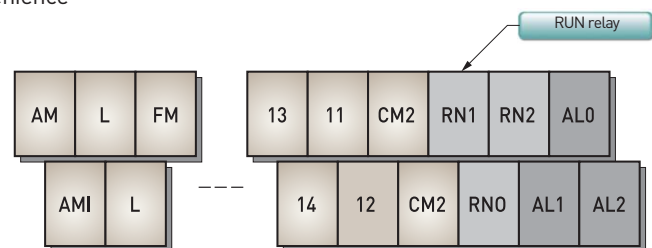

### 12 user group codes

- User can save the preferred codes (Max. 12) for fast and easy operation and set or adjust data in accordance with the characteristics of the loads.

### Convenient operation

- Operator
  - Large LED and convenient setting (code/parameter)
  - Noise resistant design (Max. 10m cable)
- OPE-N7 (standard) has parameter copy function.

### Maintenance

- Detachable cooling fan and independent DC bus capacitor make replacement and maintenance easy and simple



- Adoption of detachable control circuit terminals



## :: Flexible Adaptability for Various Environments

### Various environments

- Noise
  - Noise filter (EMC filter) comes as option
  - Realization of low noise in the main and control circuit by adopting the circuit simulation technology
- Harmonic
  - AC and DC reactor for harmonic restriction is option

### Built-in BRD regenerative braking circuit

- BRD regenerative circuit is built-in (5.5KW ~ 22KW)

### Powerful communication mode

- Circuit and individual terminal for RS485 / RS232C / CAN communication
- RS485 communication with Mod bus-RTU protocol can control upto 32 inverters

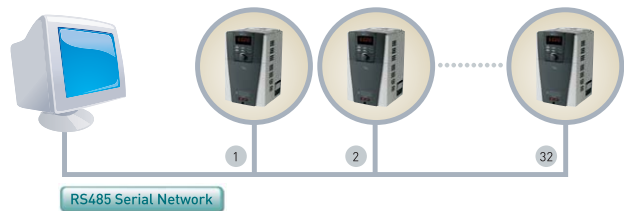

- Profibus (Option)
  - Connectable with PLC/ DCS / SCADA
  - [Easy application thanks to supply of product profile (GSD)]
  - GSD: Generic Station Description
  - Card built-in type (not require additional power board)

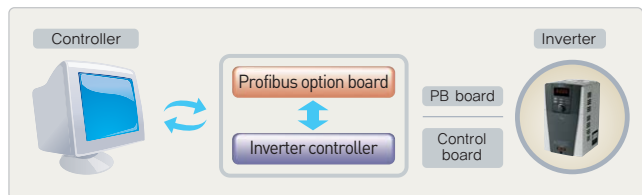

### Various environments

- HIMS (Hyundai Inverter Management System)
  - PC based Management System

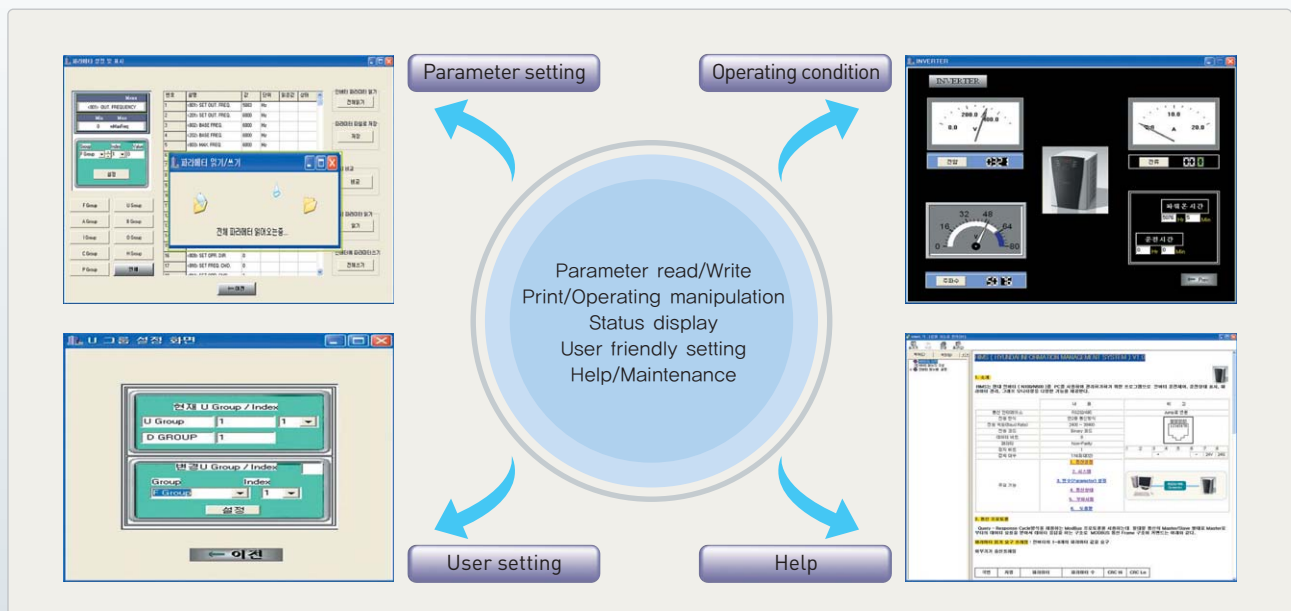

## :: Various load compatibility

- N700 series inverter can be applied to various loads.
- Just by selecting the preset code by load, N700 series will be optimized for the load.

### Conveyor & transport machine

#### Conveyor

- Multi relay output terminal
- Accurate acceleration & deceleration
- Overweight prevention by using over-torque signal
- Load sliding prevention by curve operating

#### Elevator and Parking Machine

- Multi step speed driving (slow, normal, fast)
- Overload protection by over-torque signal
- Load sliding prevention by high speed torque response
- High torque output at extremely slow speed range

#### Crane & Hoist

- High starting torque of 200% or greater at 0.5 Hz
- Slip protection function (vector control)
- Multi speed operation (1~15 speed)
- Frequency arrival signal output (motor brake on/off)
- Built-in BRD for crane (22kW and under), braking resistor

#### Factory automation

- Factory automation with PLC
- Lifting and traveling switching operation
- High speed torque response for slip down prevention
- Soft Start/Stop

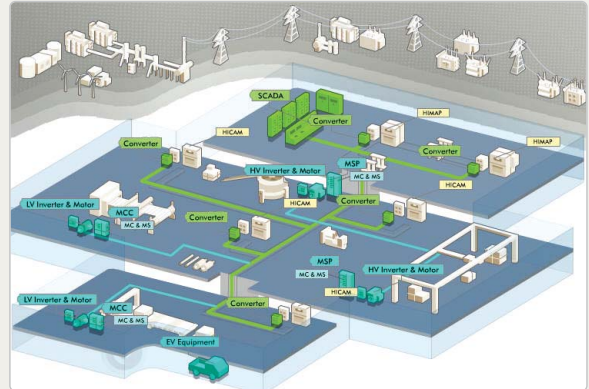

### Metal & General Machinery

#### Metal spreader

- Over current protection
- Soft Start/Stop
- Direct and various braking method selection

#### Wire elongating & winding M/C

- Powerful operation at low speed
- Sensored vector control, line speed control, location control
- System construction by application control board

#### Press, Cutter

- Powerful DC braking for user protection
- Powerful starting torque
- 15 intelligent input-output terminals for precision control [ input (1~8, FW), output (11~14, AL, RN) ]

#### Centrifugal separator & agitator

- Stable operation at wide frequency range (0.1~400Hz)
- Machine protection by a built-in regenerative braking unit (below 22kW)
- Precise acceleration & deceleration and multi-speed setting



## FAN · PUMP

### Air conditioning & dust collecting fan

- Energy saving by selecting torque characteristic of a load
- Restart function when an input power is interrupted
- Machine protection by Soft Start/Stop
- Auto operation by precise PID control function
- Low noise operation
- Quick responsiveness to load change by frequency jump and multi speed operation

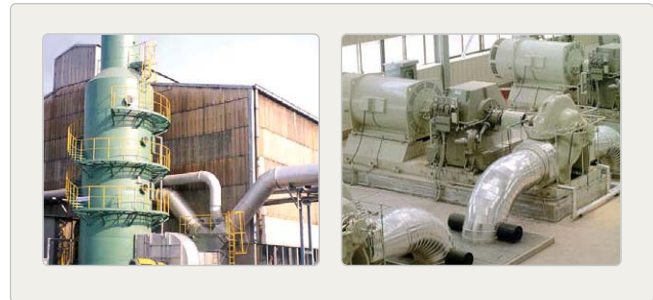

### Cooling tower

- Stable operation by high quality energy supply
- Energy saving by speed and torque control
- System circumstance protection function

Water supply pump  
Cooling water circulation pump  
Boiler water supply pump

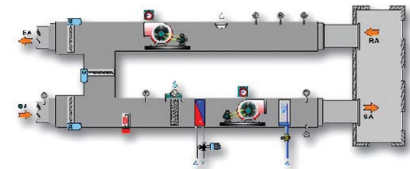

## Textile machine

### Spinning Machine

- Soft Start/Stop for prevention of snap and cut off
- Unit design for bad circumstance (dust, cotton)
- Improvement of product quality by stable operating speed

### Tender & Sewing machine

- Regular tension control function and load short protection function
- Accurate speed and torque control to improve product quality
- Synchronized control and PID control function

## Washing machine

### Washing machine

- Powerful torque boost function
- Over torque limit function
- Separate setting of acceleration and deceleration time
- Built-in regenerative braking unit (below 22kW)
- Soft Start/Stop



## Standard 200V class

INVERTER MODEL (N700-□□□LF)		055LF	075LF	110LF	150LF	185LF	220LF	300LF	370LF	450LF	550LF
Applicable Motor (4P, kW)		5.5	7.5	11	15	18.5	22	30	37	45	55
Rated Capacity (kVA)	200V	8.3	11	15.9	22.1	26.3	32.9	41.9	50.2	63	76.2
	240V	9.9	13.3	19.1	26.6	31.5	39.4	50.2	60.2	75.8	91.4
Rated output voltage		3phase 200~240V (±10%) 50/60Hz									
Rated input voltage		3phase 200~240V (This corresponds to supply voltage.)									
Rated output current (A)		24	32	46	64	76	95	121	145	182	220
Braking	Dynamic braking (short-time)	Built-in BRD circuit (The discharging resistor is optional.)						External dynamic braking unit (option)			
	Minimum value of resistor (Ω)	17	17	17	8.7	6	6	3.5	3.5	2.4	2.4
Weight (kg)		7	7	7	15	15	15	25	37	37	51
Dimension (mm) (WxDxH)		182 x 336 x 195			290 x 478 x 230			330 x 580 x 250	400 x 610 x 260		440 x 650 x 270
Control method		space vector modulation PWM system									
Output frequency range		0.1~400Hz									
Frequency accuracy		Digital : ±0.01% of Max. frequency, Analog : ±0.2% (25±10°C)									
Frequency resolution		Digital setting : 0.01Hz, Analog setting : Max. frequency / 4,000									
Voltage/frequency characteristic		V/f control (constant torque, reduced torque), free V/f control, sensorless vector control									
Overload capacity		150%/60sec									
Acceleration/Deceleration time		0.1~3600. Sec (Linear/curve setting)									
DC Braking		Performs at start; under set frequency at deceleration, via an external input (braking force, time and operating frequency)									
Input	Frequency setting	Operator	Set by up/ down key								
		External signal	Input voltage : DC 0~+10V, -10~+10V (Input impedance 10KΩ) / Input current : 4~20mA (Input impedance 180Ω)								
	Forward	Operator	Run key/ Stop key (Change FW/RV by function command)								
	Reverse	External signal	FW RUN/STOP (No contact), RV set by terminal assignment (NO/NC selection), 3-wire input possible								
	Start/stop	External port	Set by RS485								
Intelligent input terminal	FW and 8 terminal selection :										
	RV (Reverse), CF1~CF4 (Multispeed command), JG (Jogging), DB (External DC braking), SET (Second motor constants setting), 2CH (Second accel./decel.), FRS (Free-run-stop), EXT (External trip), USP (Unattended start protection), CS (Change to/from commercial power supply), SFT (Software lock), AT (Analog input selection), SET3 (Third motor constants setting), RS (Reset), STA (3-wire start), STP (s-wire stop), F/R (3-wire fwd./rev.), PID (PID On/Off), PIDC (PID reset), CAS (Control gain setting), UP/DWN (Remote-controlled accel./decel.), UDC (Remote-controlled data clearing), OPE (Operator control), SF1~SF7 (Multispeed bit command 1~7), OLR (Overload limit change), TL (Torque limit change), TRQ1, TRQ2 (Torque limit selection (1),(2)), PPI (P/PI selection), BOK (Brake verification), ORT (Orientation), LAC (LAD cancel), PCLR (Positioning deviation reset), STAT (90-degree phase difference permission), XT1, XT2, XT3 (Multi-step accel./decel. time 1~3)										
	Thermistor input terminal										
Output	4 Open collector terminals and 2 relay (c contact) selection :										
	Run (Run signal), FA1 (Frequency arrival signal (at the set frequency)), FA2 (Frequency arrival signal (at or above the set frequency)), OL (Overload advance notice signal), OD (Output deviation for PID control), ALM (Alarm signal), FA3 (Frequency arrival signal (only at the set frequency)), OTQ (Over-torque), IP (Instantaneous power failure signal), UV (Under-voltage signal), TRQ (In torque limit), RNT (Operation time over), ONT (Plug in timeout), THM (Thermal alarm), BRK (Brake release), BER (Brake error), ZS (Zero speed), DSE (Speed deviation excessive), POK (Positioning completion), FA4 (Arrival signal for over setting frequency 2), A5 (Arrival signal for only setting frequency 2), OL2 (Overload advance notice signal 2), PALM (Instantaneous power failure alarm signal), UVALM (Under voltage alarm signal)										
	Intelligent output terminal										
Intelligent output terminal		Analog voltage, analog current, pulse line output									
Display monitor		Output frequency, Output current, Motor torque, Scaled value of output frequency, Trip history, I/O terminal condition, Input power, Output voltage									
Main functions		V/f free-setting (up to 7 points), Frequency upper/lower limit, Frequency jump, Accel./decel. curve selection, Manual torque boost level/braking point setting, Analog meter tuning, Start frequency setting, Carrier frequency setting, Electronic thermal, Free-setting, External start/end frequency (frequency rate setting), Analog input selection, Retry after trip, Restart after instantaneous power failure, Various signal outputs, Reduced voltage start, Overload restriction, Default value setting, automatic deceleration and stop at power failure, AVR function, Auto-tuning									
Protective functions		Over-current protection, Over-voltage, Under-voltage, Electronic thermal, Temperature error, Ground fault current at start, Instantaneous power failure, USP error, Phase loss error, Braking resistor overload, External trip, Option error and Communication error									
Standard application		Low voltage directive 72/73/EEC & EMC Directive 2004/108/EC, CE, UL, cUL									
Environmental conditions	Ambient operating/storage temperature/humidity	-10 ~ 50°C / -20 ~ 65°C / 20 ~ 90% RH (Non-condensing)									
	Vibration	5.9% (0.6G), 10~55Hz (5.5~22kW)						2.94m/S <sup>2</sup> (0.3G), 10~55Hz (30~132kW)			
	Location	Less than 1000m above sea level, indoors (no corrosive gas nor dust)									
Color		DIC-582 (upper case), DIC-P819 (lower case)									
Options	Internal	Feedback PCB, Profibus PCB									
	External	Braking unit, AC reactor, DC reactor, EMC filter, Operator cable, Harmonic control unit, Radio noise filter, LCR filter, Braking resistor, Analog manipulation panel, Application control unit									
Operator		OPE-N7 (4-digit LED)									

## Standard 400V class

INVERTER MODEL (N700-□□□LF)		055HF	075LF	110HF	150HF	185HF	220HF	300HF	370HF	450HF	550HF	750HF	900HF	1100HF	1320HF		
Applicable Motor(4P, kW)		5.5	7.5	11	15	18.5	22	30	37	45	55	75	90	110	132		
Rated Capacity (kVA)	400V	8.3	11.0	15.9	22.1	26.3	33.2	41.9	50.2	63.0	76.2	103.2	121.9	150.3	180.1		
	480V	9.9	13.3	19.1	26.6	31.5	39.9	50.2	60.2	75.8	91.4	123.8	146.3	180.4	216.1		
Rated output voltage		3phase 380~480V(±10%) 50/60Hz															
Rated input voltage		3phase 380~480V(This corresponds to supply voltage.)															
Rated output current(A)		12	16	23	32	38	48	58	75	90	110	149	176	217	260		
Braking	Dynamic braking(short-time)	Built-in BRD circuit(The discharging resistor is optional.) External dynamic braking unit (option)															
	Minimum value of resistor(Ω)	70	50	50	30	20	20	12	12	8	8	6	6	6	6		
Weight(kg)		7	7	7	15	15	15	25	37	37	51	70	70	90	90		
Dimension(mm) (W x D x H)		182x336x195			290x478x230			330x580x250		400x610x260		440x650x271		420x740x320		500x780x320	
Control method		space vector modulation PWM system															
Output frequency range		0.1~400Hz															
Frequency accuracy		Digital : ±0.01% of Max. frequency, Analog : ±0.2%(25±10°C)															
Frequency resolution		Digital setting : 0.01HZ, Analog setting : Max. frequency / 4,000															
Voltage/frequency characteristic		V/f control (constant torque, reduced torque), free V/f control, sensorless vector control															
Overload capacity		150%/60sec															
Acceleration/Deceleration time		0.1~3600. Sec (Linear/curve setting)															
DC Braking		Performs at start;under set frequency at deceleration, via an external input (braking force, time and operating frequency)															
Input	Frequency setting	Operator	Set by up/ down key														
		External signal	Input voltage : DC 0~+10V, -10~+10V(Input impedance 10KΩ) / Input current : 4~20mA(Input impedance 180Ω)														
	Forward/Reverse	Operator	Run key/ Stop key (Change FW/RV by function command)														
	Start/stop	External signal	FW RUN/STOP (No contact), RV set by terminal assignment (NO/NC selection), 3-wire input possible														
		External port	Set by RS485														
Input	Intelligent input terminal		FW and 8 terminal selection : RV(Reverse), CF1~CF4(Multispeed command), JG(Jogging), DB(External DC braking), SET(Second motor constants setting), 2CH(Second accel./decel.), FRS(Free-run-stop), EXT(External trip), USP(Unattended start protection),CS(Change to/from commercial power supply), SFT(Software lock), AT(Analog input selection), SET3(Third motor constants setting), RS(Reset), STA(3-wire start), STP(s-wire stop), F/R(3-wire fwd./rev.), PID(PID On/Off), PIDC(PID reset), CAS(Control gain setting), UP/DWN(Remote-controlled accel./decel.), UDC(Remote-controlled data clearing), OPE(Operator control), SF1~SF7(Multispeed bit command 1~7), OLR(Overload limit change), TL(Torque limit change), TRQ1, TRQ2(Torque limit selection(1),(2))PP(P/PI selection), BOK(Brake verification), ORT(Orientation), LAC(LAD cancel), PCLR(Positioning deviation reset), STAT(90-degree phase difference permission), XT1, XT2, XT3 (Multi-step accel./decel. time 1~3)														
	Thermistor input terminal		1 terminal( PTC characteristics)														
	Output	Intelligent output terminal		4 Open collector terminals and 2 relay (c contact) selection : Run(Run signal), FA1(Frequency arrival signal(at the set frequency)), FA2(Frequency arrival signal(at or above the set frequency)), OL(Overload advance notice signal), OD(Output deviation for PID control), ALM(Alarm signal), FA3(Frequency arrival signal(only at the set frequency)), OTQ(Over-torque), IP(Instantaneous power failure signal), UV(Under-voltage signal), TRQ(In torque limit), RNT(Operation time over), ONT(Plug in timeover), THM(Thermal alarm), BRK(Brake release), BER(Brake error), ZS(Zero speed), DSE(Speed deviation excessive), POK(Positioning completion), FA4(Arrival signal for over setting frequency2), A5(Arrival signal for only setting frequency2), OL2(Overload advance notice signal2), PALM(Instantaneous power failure alarm signal), UVALM(Under voltage alarm signal)													
Intelligent output terminal		Analog voltage, analog current, pulse line output															
Display monitor		Output frequency, Output current, Motor torque, Scaled value of output frequency, Trip history, I/O terminal condition, Input power, Output voltage															
Main functions		V/f free-setting (up to 7 points), Frequency upper/lower limit, Frequency jump, Accel./decel.curve selection, Manual torque boost level/braking point setting, Analog meter tuning, Start frequency setting, Carrier frequency setting, Electronic thermal, Free-setting, External start/end frequency(frequency rate setting), Analog input selection, Retry after trip, Restart after instantaneous power failure, Various signal outputs, Reduced voltage start, Overload restriction, Default value setting, automatic deceleration and stop at power failure, AVR function, Auto-tuning															
Protective functions		Over-current protection, Over-voltage, Under-voltage, Electronic thermal, Temperature error, Ground fault current at start, Instantaneous power failure, USP error, Phase loss error, Braking resistor overload, External trip, Option error and Communication error															
Standard application		Low voltage directive 72/73/EEC & EMC Directive 2004/108/EC, CE, UL, cUL															
Environmental conditions	Ambient operating/storage temperature/humidity		-10 ~ 50°C / -20 ~ 65°C / 20 ~ 90% RH (Non-condensing)														
	Vibration		5.9% (0.6G), 10~55Hz(5.5~22kW)						2.94m/S2(0.3G), 10~55Hz(30~132kW)								
	Location		Less than 1000m above sea level, indoors (no corrosive gas nor dust)														
Color		DIC-582(upper case), DIC-P819(lower case)															
Options	Internal		Feedback unit, Profibus unit														
	External		Braking unit, AC reactor, DC reactor, EMC filter, Operator cable, Harmonic control unit, Radio noise filter, LCR filter, Braking resistor, Analog manipulation panel, Application control unit														
Operator		OPE-N7(4line LED)															

# | DIMENSION |

## N700-055LF/055HF, N700-075LF/075HF N700-110LF/110HF Dimension

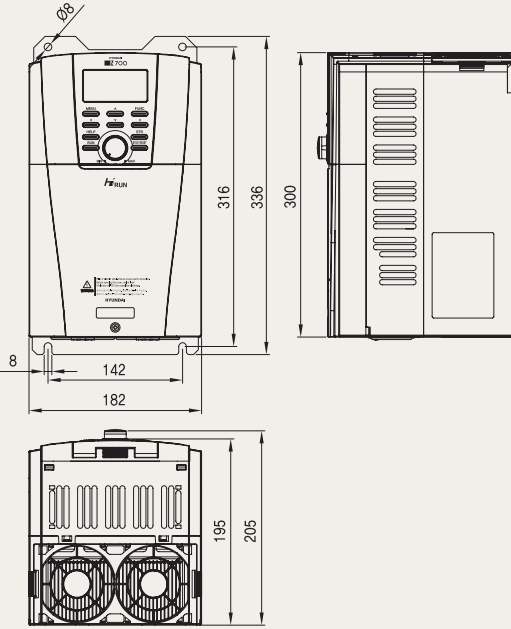

## N700-150LF/150HF, N700-185LF/185HF N700-220LF/220HF Dimension

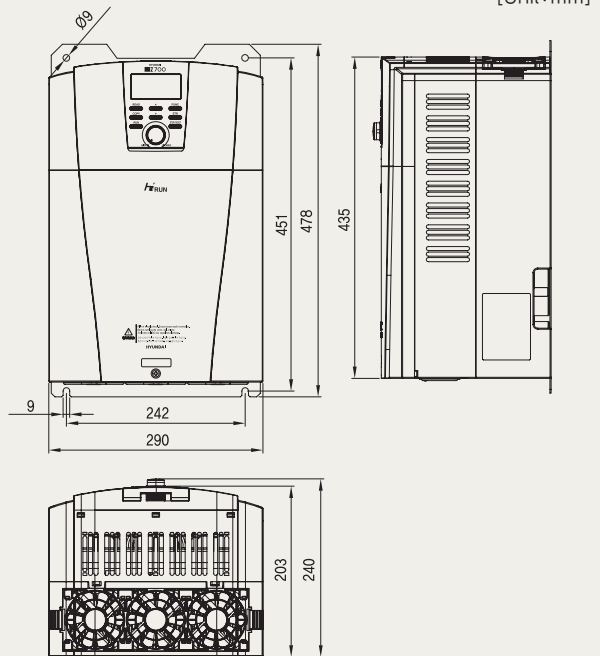

[Unit: mm]

## N700-300LF/300HF Dimension

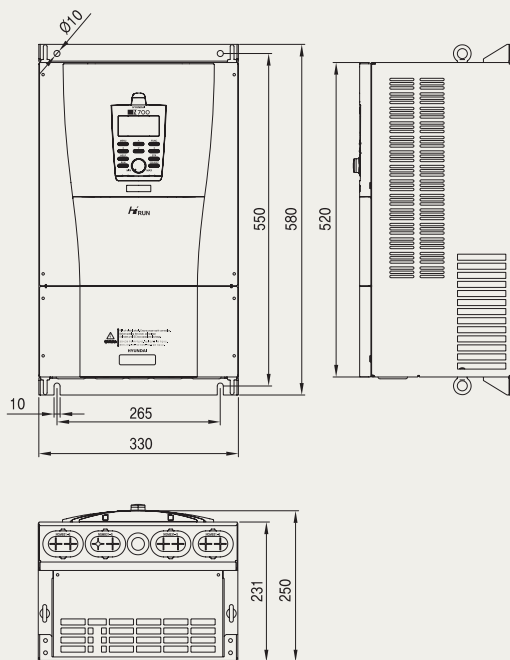

## N700-370LF/370HF N700-450LF/450HF Dimension

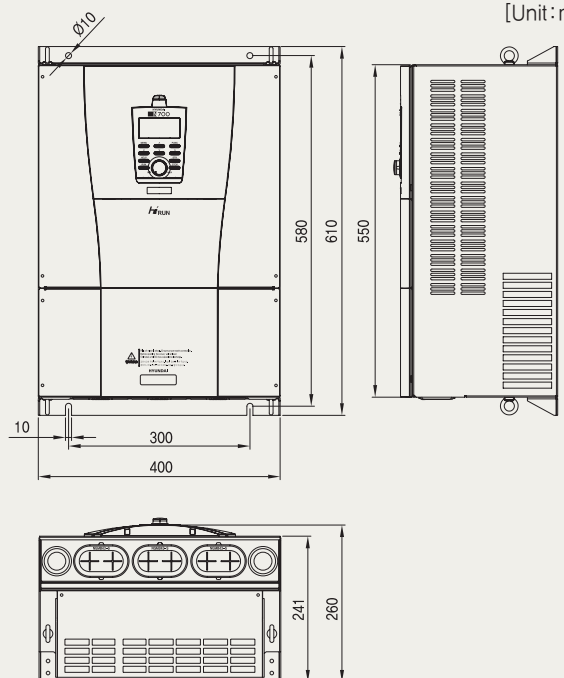

[Unit: mm]

N700-550LF/550HF Dimension

N700-750HF/900HF Dimension

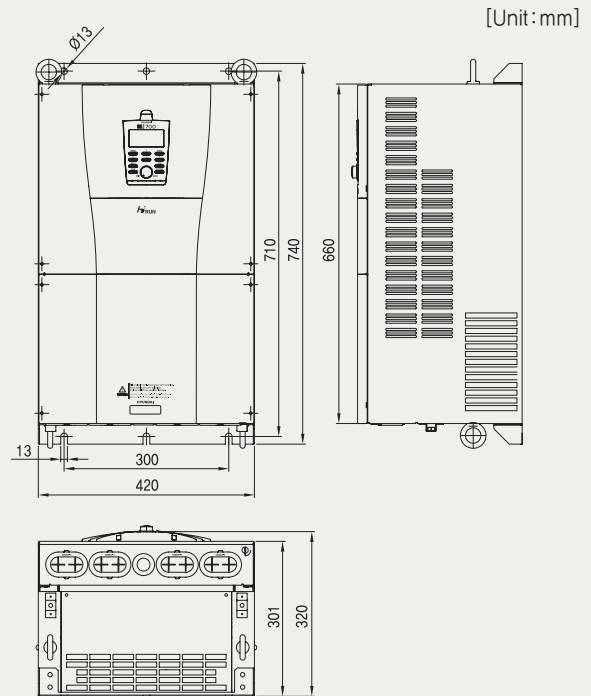
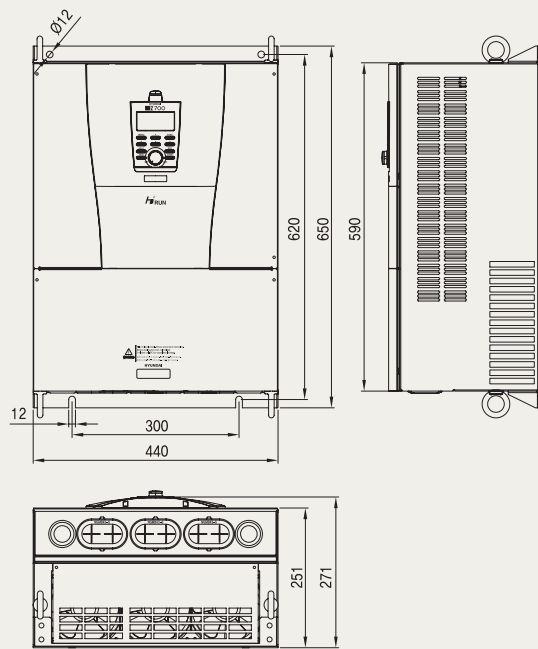

N700-1100HF/1320HF Dimension

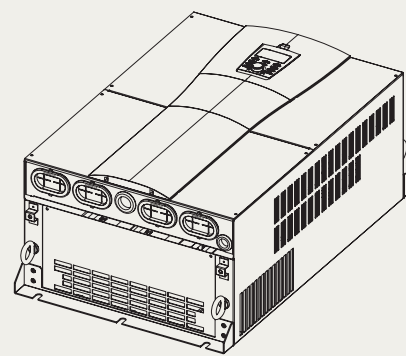
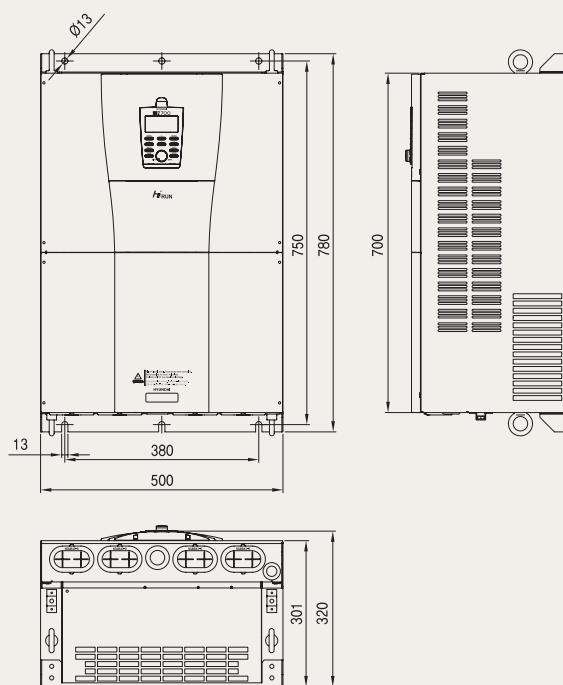

\* The LED type of digital operator(OPE-N7) comes as standard.

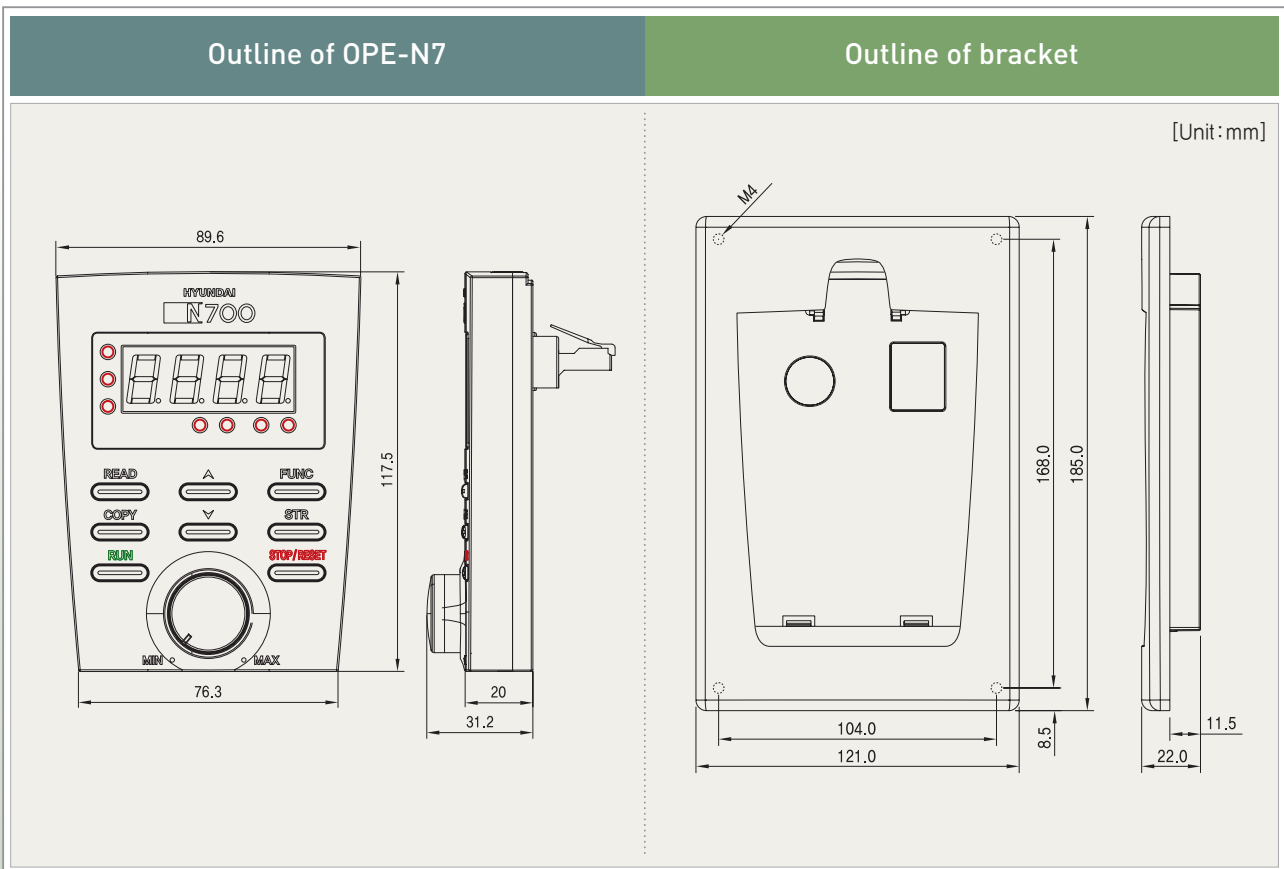
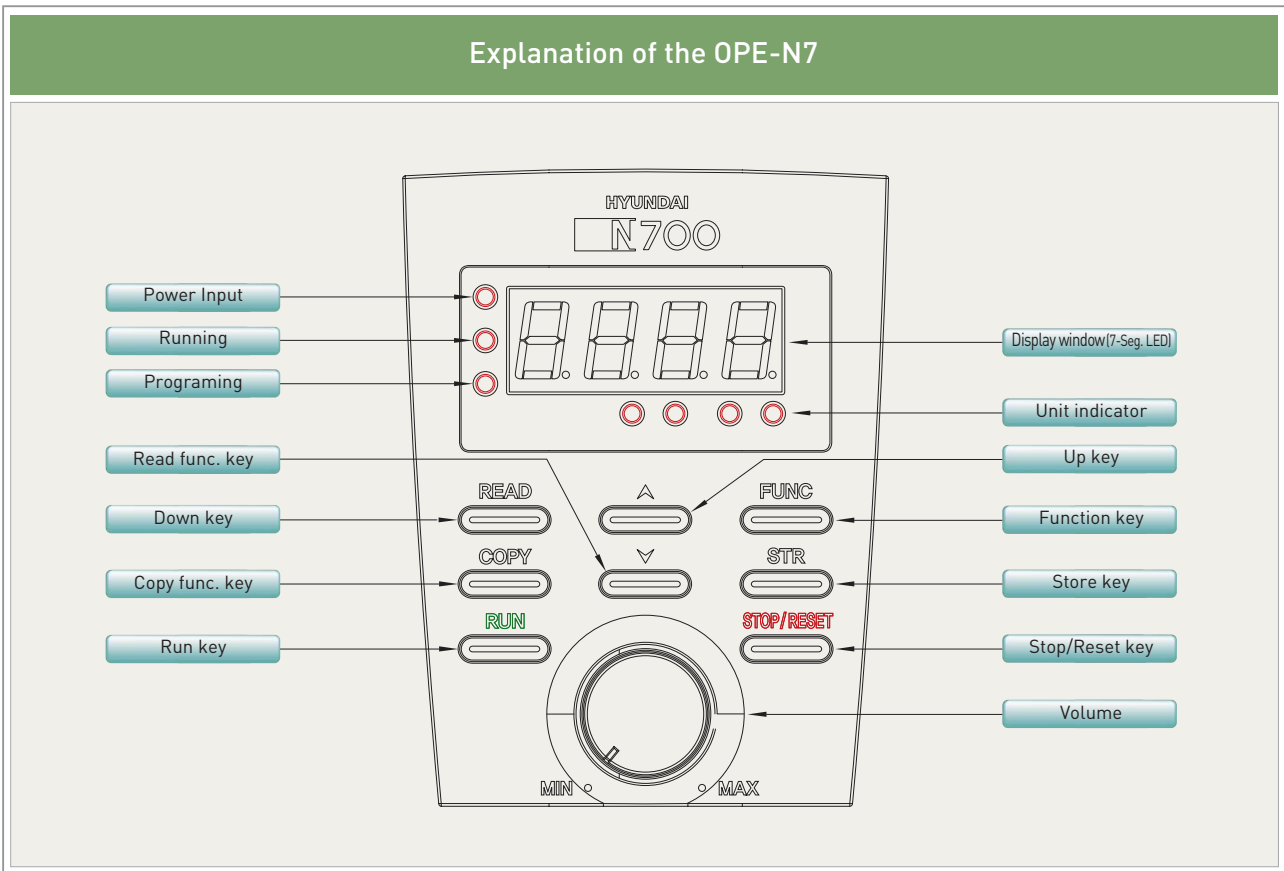

### Change between function mode

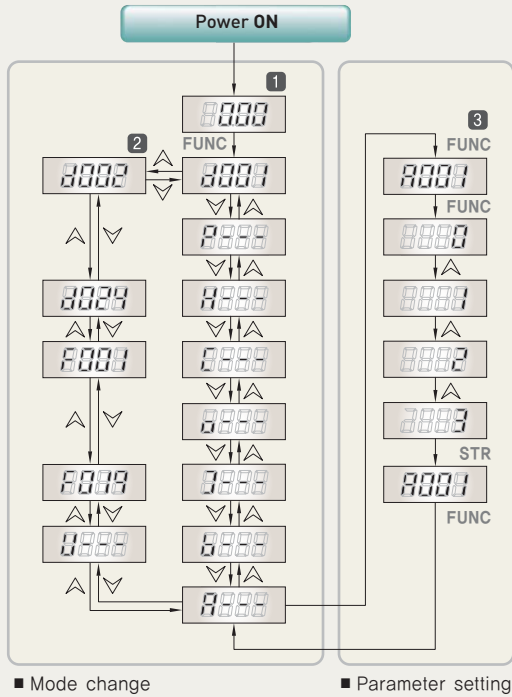

#### 1 Initial value

- Display of parameter value set when power is on.
- Display of output frequency d001 : 0.00 [Hz]

#### 2 Change between function modes

- Function mode is changed by using the **FUNC** key and the **UP/DOWN** key.
- Display of Function code by pushing **FUNC** key at set value (ex: 0.00 → push the **FUNC** key 1 time → d001 )
- Monitor mode is displayed by pushing the **FUNC** key (ex: A001 → push the **FUNC** key 1 time → A--- )  
 ※ Except the monitor mode and F-Group.
- Monitor mode is displayed by pushin A↔B↔I↔o↔C↔H↔P.

### Start-up operation

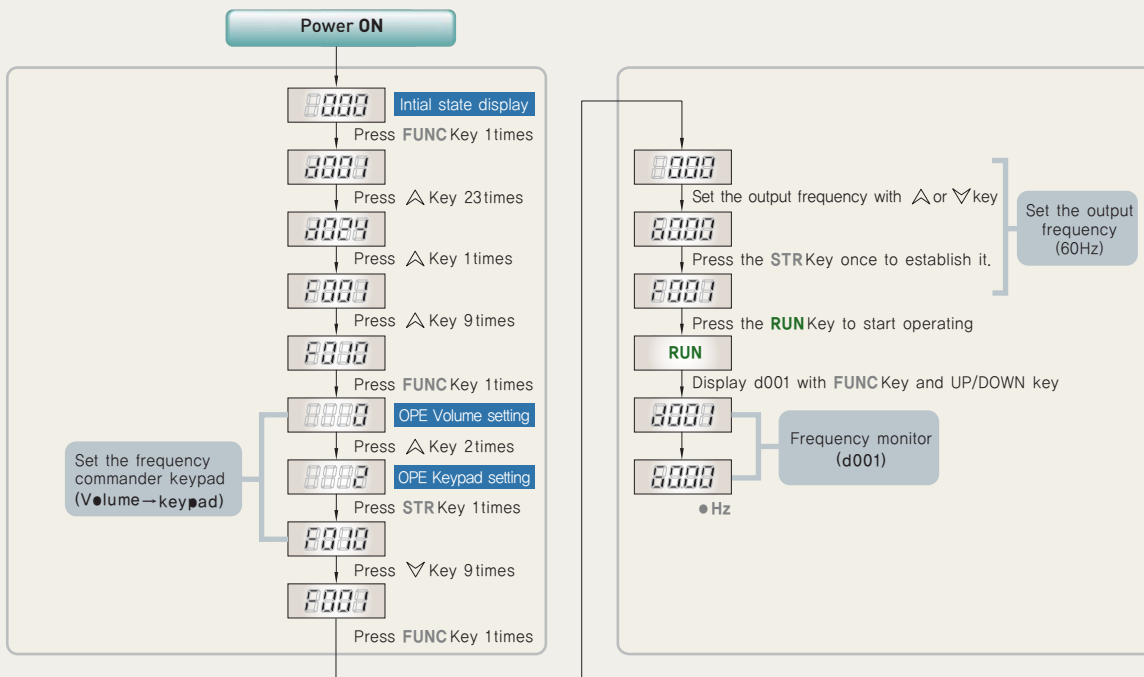

## Monitor mode (D-group)

Main function	Code	Function name	Description	Initial Data	Change mode on run
<b>Display Group</b>					
Basic monitor	d001	Output frequency monitor	0~99.99/100.0~400.0[Hz]	0.00	0.00
	d002	Motor rotational direction monitor	F(forward), R(reverse), O(stop)	F	F
	d003	Output current monitor	0.0~999.9[A]	0.0	0.0
	d004	Output voltage monitor	0.0~999.9[V]	0.0	0.0
	d005	DC link voltage monitor	0.0~999.9[V]	0.0	0.0
	d006	Motor input power monitor	0.0~999.9[Kw]	0.0	0.0
	d007	Output torque monitor	-300~300[%]	0	0
	d008	Number of motor rotation	0~9999[RPM]	0	0
	d009	PID Feedback monitor	0.00~100.0(= PID F/By×C026) [%]	0	0
	d010	Intelligent input terminal monitor	Display the state of the intelligent input terminals	-	-
	d011	Intelligent output terminal monitor	Display the state of the intelligent output terminals	-	-
	d012	Frequency conversion monitor	0.00~99.99/100.0~400.0(= d001xb009)	0	0
	d013	Accumulated time monitor during RUN(Hr)	0~9999./1000~6553[Hr]	0	0
	d014	Accumulated time monitor during RUN(Min)	0~59[Min]	0	0
	d015	Power on time monitor(Hr)	0~9999./1000~6553[Hr]	0	0
	d016	Power on time monitor(Min)	0~59[Min]	0	0
<b>Trip &amp; Warning Monitor</b>					
Trip & Warning Monitor	d017	IGBT temperature monitor	0~9999[°C]	-	-
	d018	Trip counter	Display the number of inverter trips.	0	0
	d019	Trip monitor 1	Display the details for the last six protective trips. Trip code, output frequency [Hz], output current [A], the direct voltage (between P and N) on tripping[V].	-	-
	d020	Trip monitor 2		-	-
	d021	Trip monitor 3		-	-
	d022	Trip monitor 4		-	-
	d023	Trip monitor 5		-	-
	d024	Trip monitor 6		-	-



**HYUNDAI INVERTER**  
N700 Series

## Fundamental and operating curve setting (F&A-group)

Main function	Code	Function name	Setting range	Initial Data	Change mode on run
Output frequency	F001	Output frequency setting	0.00~99.99/100.0~400.0[Hz]	0.00	○
	F201	Output frequency setting, 2nd motor	0.00~99.99/100.0~400.0[Hz]	0.00	○
Basic setting	F002	Base frequency setting	30.00~99.99/100.0~400.0, up to max. frequency[Hz]	60.00	×
	F202	Base frequency, 2nd motor	30.00~99.99/100.0~400.0, up to max. frequency[Hz]	60.00	×
	F003	Maximum frequency setting	30.00~99.99/100.0~400.0, from base frequency[Hz]	60.00	×
	F203	Maximum frequency setting, 2nd motor	30.00~99.99/100.0~400.0, from base frequency[Hz]	60.00	×
	F004	Starting frequency setting	0.10~10.0[Hz]	0.50	○
	F005	Frequency upper limit	0.00~99.99/100.0~400.0[Hz] Frequency min. ~ Max. frequency	0.00	○
	F205	Frequency upper limit, 2nd motor	0.00~99.99/100.0~400.0[Hz] Frequency min. ~ Max. frequency	0.00	○
	F006	Frequency lower limit	0.00~99.99/100.0~400.0[Hz] Starting frequency ~ Max. frequency	0.00	○
	F206	Frequency lower limit, 2nd motor	0.00~99.99/100.0~400.0[Hz] Starting frequency ~ Max. frequency	0.00	○
Acceleration deceleration time setting	F007	Accelerating time setting	0.1~999.9,1000.~3600.[sec]	30.0	○
	F207	Accelerating time setting, 2nd motor	0.1~999.9,1000.~3600.[sec]	30.0	○
	F008	Decelerating time setting	0.1~999.9,1000.~3600.[sec]	30.0	○
	F208	Decelerating time setting, 2nd motor	0.1~999.9,1000.~3600.[sec]	30.0	○
Basic setting	F009	Driving direction selection	0(FWD), 1(REV)	0	×
	F010	Frequency source selection	0(OPE VOL),1(TERMINAL),2(OPE KEYPAD),3(COM),4(OPT1),5(OPT2)	0	×
	F011	RUN command source selection	1(TERMINAL),2(OPE),3(COM),4(OPT1),5(OPT2)	2	×
Motor information	F012	Motor control method	0(VC),1(VP1),2(VP2),3(FREE V/f),4(SLV-I),5(SLV-D),6(V2),7(0Hz-V2)	0	×
	F212	2nd motor control method	0(VC),1(VP1),2(VP2),3(FREE V/f),4(SLV-I),5(SLV-D)	0	×
Motor setting	F013	Motor voltage selection (Motor rated voltage)	200/215/220/230/240[V] 380/400/415/440/460/480[V]	220 (440)	×
	F014	Output voltage gain	20~100[%]	100	○
	F015	Motor capacity selection (Motor rated capacity)	1.5/2.2/3.7/5.5/7.5/11/15/18.5/22/30/37/45/55/75 /90/110/132/160[Kw]	Factory setting	×
	F215	2nd Motor capacity selection (Second motor rated capacity)	1.5/2.2/3.7/5.5/7.5/11/15/18.5/22/30/37/45/55/75 /90/110/132/160[Kw]	Factory setting	×
	F016	Motor pole selection	2/4/6/8/10/12[Pole]	4	×
	F216	2nd motor pole selection	2/4/6/8/10/12[Pole]	4	×
	F017	Motor rated current setting	0.0~999.9[A]	Factory setting	×
	F217	2nd motor rated current	0.0~999.9[A]	Factory setting	×
	F018	Speed/Torque mode selection	0(Speed control mode)/1(Torque control mode)	0	×
	F019	SLV control method selection	0(Normal operation mode), 1(0Hz operation mode)	0	×
Acceleration deceleration pattern setting	A001	Acceleration pattern	0(Line), 1(S_Curve), 2(U_Curve), 3(RU_Curve)	0	×
	A201	Acceleration pattern, 2nd motor	0(Line), 1(S_Curve), 2(U_Curve), 3(RU_Curve)	0	×
	A002	Deceleration pattern	0(Line), 1(S_Curve), 2(U_Curve), 3(RU_Curve)	0	×
	A202	Deceleration pattern, 2nd motor	0(Line), 1(S_Curve), 2(U_Curve), 3(RU_Curve)	0	×
	A003	Acceleration curvature	1~10	8	×
Acceleration stop setting	A004	Deceleration curvature	1~10	8	×
	A005	Acceleration stop frequency	0.00~Max. Frequency[Hz]	0.00	○
Acceleration deceleration setting 2	A006	Acceleration stop time	0~60.00[sec]	0.00	○
	A007	Acceleration /Deceleration selection 2	0(2 Channel), 1(A010/A011)	0	×
	A207	Acceleration /deceleration 2 selection, 2nd motor	0(2 Channel), 1(A010/A011)	0	×
	A008	Acceleration time 2	0.1~999.9,1000.~3600.[sec]	30.0	○
	A208	Acceleration time 2, 2nd motor	0.1~999.9,1000.~3600.[sec]	30.0	○
	A009	Deceleration time 2	0.1~999.9,1000.~3600.[sec]	30.0	○
	A209	Deceleration time 2, 2nd motor	0.1~999.9,1000.~3600.[sec]	30.0	○
	A010	Acceleration frequency 2	0.00~99.99/100.0~400.0[Hz]	0.00	×
	A210	Acceleration frequency 2, 2nd motor	0.00~99.99/100.0~400.0[Hz]	0.00	×
	A011	Deceleration frequency 2	0.00~99.99/100.0~400.0[Hz]	0.00	×
	A211	Deceleration frequency 2, 2nd motor	0.00~99.99/100.0~400.0[Hz]	0.00	×
Acceleration deceleration setting 3	A012	Acceleration /Deceleration Selection 3	0(3 Channel), 1(A015/A016)	0	×
	A013	Acceleration time 3	0.1~999.9,1000.~3600.[sec]	30.0	○
	A014	Deceleration time 3	0.1~999.9,1000.~3600.[sec]	30.0	○
	A015	Acceleration frequency 3	0.00~99.99/100.0~400.0 [Hz]	0.00	×
	A016	Deceleration frequency 3	0.00~99.99/100.0~400.0 [Hz]	0.00	×

## Fundamental and operating curve setting (F&A-group)

Main function	Code	Function name	Setting range	Initial Data	Change mode on run
Multi-speed frequency setting	A027	Multi-speed frequency 0	F001 same setting value, 0.00~99.99/100.0~400.0[Hz] Start frequency ~ Max. frequency	0.00	○
	A028	Multi-speed frequency 1	0.00~99.99/100.0~400.0[Hz], Start frequency ~ Max. frequency	0.00	○
	A029	Multi-speed frequency 2	0.00~99.99/100.0~400.0[Hz], Start frequency ~ Max. frequency	0.00	○
	A030	Multi-speed frequency 3	0.00~99.99/100.0~400.0[Hz], Start frequency ~ Max. frequency	0.00	○
	A031	Multi-speed frequency 4	0.00~99.99/100.0~400.0[Hz], Start frequency ~ Max. frequency	0.00	○
	A032	Multi-speed frequency 5	0.00~99.99/100.0~400.0[Hz], Start frequency ~ Max. frequency	0.00	○
	A033	Multi-speed frequency 6	0.00~99.99/100.0~400.0[Hz], Start frequency ~ Max. frequency	0.00	○
	A034	Multi-speed frequency 7	0.00~99.99/100.0~400.0[Hz], Start frequency ~ Max. frequency	0.00	○
	A035	Multi-speed frequency 8	0.00~99.99/100.0~400.0[Hz], Start frequency ~ Max. frequency	0.00	○
	A036	Multi-speed frequency 9	0.00~99.99/100.0~400.0[Hz], Start frequency ~ Max. frequency	0.00	○
	A037	Multi-speed frequency 10	0.00~99.99/100.0~400.0[Hz], Start frequency ~ Max. frequency	0.00	○
	A038	Multi-speed frequency 11	0.00~99.99/100.0~400.0[Hz], Start frequency ~ Max. frequency	0.00	○
	A039	Multi-speed frequency 12	0.00~99.99/100.0~400.0[Hz], Start frequency ~ Max. frequency	0.00	○
	A040	Multi-speed frequency 13	0.00~99.99/100.0~400.0[Hz], Start frequency ~ Max. frequency	0.00	○
	A041	Multi-speed frequency 14	0.00~99.99/100.0~400.0[Hz], Start frequency ~ Max. frequency	0.00	○
A042	Multi-speed frequency 15	0.00~99.99/100.0~400.0[Hz], Start frequency ~ Max. frequency	0.00	○	
Multi-speed Acceleration deceleration time setting	A043	Multi-speed 1 acceleration time	0.1~999.9/1000.~3600.[sec]	30.0	○
	A044	Multi-speed 1 deceleration time	0.1~999.9/1000.~3600.[sec]	30.0	○
	A045	Multi-speed 2 acceleration time	0.1~999.9/1000.~3600.[sec]	30.0	○
	A046	Multi-speed 2 deceleration time	0.1~999.9/1000.~3600.[sec]	30.0	○
	A047	Multi-speed 3 acceleration time	0.1~999.9/1000.~3600.[sec]	30.0	○
	A048	Multi-speed 3 deceleration time	0.1~999.9/1000.~3600.[sec]	30.0	○
	A049	Multi-speed 4 acceleration time	0.1~999.9/1000.~3600.[sec]	30.0	○
	A050	Multi-speed 4 deceleration time	0.1~999.9/1000.~3600.[sec]	30.0	○
	A051	Multi-speed 5 acceleration time	0.1~999.9/1000.~3600.[sec]	30.0	○
	A052	Multi-speed 5 deceleration time	0.1~999.9/1000.~3600.[sec]	30.0	○
	A053	Multi-speed 6 acceleration time	0.1~999.9/1000.~3600.[sec]	30.0	○
	A054	Multi-speed 6 deceleration time	0.1~999.9/1000.~3600.[sec]	30.0	○
	A055	Multi-speed 7 acceleration time	0.1~999.9/1000.~3600.[sec]	30.0	○
	A056	Multi-speed 7 deceleration time	0.1~999.9/1000.~3600.[sec]	30.0	○
Free V/F Curve setting	A059	Free V/F frequency 1	0~99.99/100.0~400.0[Hz]	0.00	×
	A060	Free V/F voltage 1	0.0~999.9[V]	0.0	×
	A061	Free V/F frequency 2	0~99.99/100.0~400.0[Hz]	0.00	×
	A062	Free V/F voltage 2	0.0~999.9[V]	0.0	×
	A063	Free V/F frequency 3	0~99.99/100.0~400.0[Hz]	0.00	×
	A064	Free V/F voltage 3	0.0~999.9[V]	0.0	×
	A065	Free V/F frequency 4	0~99.99/100.0~400.0[Hz]	0.00	×
	A066	Free V/F voltage 4	0.0~999.9[V]	0.0	×
	A067	Free V/F frequency 5	0~99.99/100.0~400.0[Hz]	0.00	×
	A068	Free V/F voltage 5	0.0~999.9[V]	0.0	×
	A069	Free V/F frequency 6	0~99.99/100.0~400.0[Hz]	0.00	×
A070	Free V/F voltage 6	0.0~999.9[V]	0.0	×	
A071	Free V/F frequency 7	0~99.99/100.0~400.0[Hz]	0.00	×	
A072	Free V/F voltage 7	0.0~999.9[V]	0.0	×	
Jogging driving setting	A073	Jogging frequency	0.00~10.00[Hz]	0.00	○
	A074	Jogging stop mode	0(FRS), 1(DEC), 2(DCBB)	0	○
Jump frequency setting	A075	Jump frequency min. 1	0.00 ~ 99.99/100.0~400.0	0.00	○
	A076	Jump frequency max. 1	0.00 ~ 99.99/100.0~400.0	0.00	○
	A077	Jump frequency min. 2	0.00 ~ 99.99/100.0~400.0	0.00	○
	A078	Jump frequency max. 2	0.00 ~ 99.99/100.0~400.0	0.00	○
	A079	Jump frequency min. 3	0.00 ~ 99.99/100.0~400.0	0.00	○
A080	Jump frequency max. 3	0.00 ~ 99.99/100.0~400.0	0.00	○	

Main function	Code	Function name	Setting range	Initial Data	Change mode on run
DC braking setting	A081	DC braking selection	0(Disable), 1(Enable)	0	○
	A082	DC braking frequency	0.00~60.00[Hz]	0.50	○
	A083	DC braking waiting time	0.0~5.0[sec]	0.0	○
	A084	DC braking force	0~100[%]	0	○
	A085	DC braking time	0.00~60.00[sec]	0.00	○
	A086	DC braking edge/level selection	0(Edge), 1(Level)	1	○
	A087	DC braking force for starting	0~100[%]	0	○
Acceleration deceleration reference	A088	DC braking time for starting	0.00~60.00[sec]	0.00	○
	A089	Acceleration /Deceleration time reference selection	0(MaxFreq), 1(ComdFreq)	0	×
Gain setting	A090	Speed control loop gain	1~300	120	×
	A091	Speed control loop constant	1~120	60	×
	A092	Speed control proportion gain setting	0~1000[%]	100	×
	A093	Speed control integration gain setting	0~1000[%]	100	×
	A094	Load selection	0(Normal), 1(Lift), 2(Washing machine), 3(Press), 4~5(Reserved mode)	0	×

## User setting functions (U-group)

Main function	Code	Function name	Setting range	Initial Data	Change mode on run
User selection mode	U001	User 1 selection	No/d001~P021	No	○
	U002	User 2 selection	No/d001~P021	No	○
	U003	User 3 selection	No/d001~P021	No	○
	U004	User 4 selection	No/d001~P021	No	○
	U005	User 5 selection	No/d001~P021	No	○
	U006	User 6 selection	No/d001~P021	No	○
	U007	User 7 selection	No/d001~P021	No	○
	U008	User 8 selection	No/d001~P021	No	○
	U009	User 9 selection	No/d001~P021	No	○
	U010	User 10 selection	No/d001~P021	No	○
	U011	User 11 selection	No/d001~P021	No	○
	U012	User 12 selection	No/d001~P021	No	○

HYUNDAI INVERTER  
N700 Series



# FUNCTION LIST

## Operating condition setting (b-group)

Main function	Code	Function name	Setting range	Initial Data	Change mode on run
Operation direction	b001	Rotational direction restriction	0(All Enable), 1(FW Enable), 2(REV Enable)	0	○
Start selection	b003	Reduced voltage start selection	0(start reduced voltage, short time)~ 6(start reduced voltage, long time)	0	○
	b004	Instantaneous power failure under-voltage retry time selection	0(Restart until 16th), 1(Unlimited Restart)	0	○
Stop and restart selection	b005	Stop key enable	0(valid), 1(Invalid)	0	○
	b006	Stop mode selection	0(Decel. Stop), 1(FRS), 2(DCBBR)	0	×
	b007	FRS selection	0(ZERO Hz), 1(Fmat (at FRS function setting)) 2(Speed search (at starting))	0	○
AVR	b008	AVR selection	0(ALWAYS En), 1(ALWAYS DIS), 2(Decel. DIS)	0	×
Frequency conversion	b009	Frequency scaling conversion factor	0.1~99.9	1.0	○
Carrier frequency	b010	Carrier frequency	0.5~10.0[kHz]	5.0	×
Fan setting	b011	Cooling fan control	0(ALWAYS En), 1(OPR. En)	0	×
	b012	Debugger mode selection	0~100	0	×
Ground fault	b013	Ground fault	0(Invalid), 1(valid)	0	×
Initialization	b014	Initialization mode	0(TRIP ONLY), 1(DATA ONLY), 2(TRIP+DATA)	0	×
	b015	Country code for initialization	0(LOCAL), 1(EC), 2(USA)	0	×
Retry setting	b016	Retry selection	0(TRIP), 1(ZERO Hz), 2(FREQ MAT), 3(F-D-TRIP)	0	○
	b017	Allow under-voltage power failure time	0.3~1.0[sec]	1.0	○
	b018	Retry wait time	0.3~100.0[sec]	1.0	○
	b019	Instantaneous power failure under-voltage trip during stop	0(Invalid), 1(Valid), 2(ST/DEC Dis) 3(Always Invalid: P-N DC)	0	○
	b020	Frequency setting to match	0~99.99/100.0~400.0[Hz]	0.00	○
	b021	Non-stop function section at Instantaneous power failure	0(Invalid), 1(valid)	0	×
	b022	Starting voltage of non-stop function at Instantaneous power failure	0.0~999.9[V]	0.0	×
	b023	Non-stop instantaneous power failure LADSTOP level	0.0~999.9[V]	0.0	×
	b024	Non-stop deceleration time at instantaneous power failure	0.1~99.99/100.0~999.9/1000~3600[sec]	1.0	×
	b025	Starting deceleration width at instantaneous power failure	0.00~10.00[Hz]	0.00	×
Electronic thermal	b026	Open phase protection selection	0(Invalid), 1(Valid)	0	○
	b027	Electronic thermal level	0.0~999.9[A]	Irate	○
	b227	Electronic thermal level, 2nd motor	0.0~999.9[A]	Irate	○
	b028	Electronic thermal characteristic selection	0(DECEL TORQ.), 1(CONST TOQR.)	1	○
	b228	Electronic thermal characteristic selection, 2nd motor	0(DECEL TORQ.), 1(CONST TOQR.)	1	○
b029	Electronic thermal warning level	0~100[%]	80	○	
Overload limit	b030	Overload restriction selection	0(Disable), 1(ACCEL/CONST), 2(CONST), 3(ACCEL/CST(RE))	1	○
	b031	Overload restriction level	Inverter rated current*0.5 ~ 2.0[times]	1.5	○
	b032	Overload restriction limit constant	0.1~30.0[sec]	3.0	○
Thermistor	b033	Overload advance notice signal output mode	0(Accel/Decel/Const), 1(Const)	0	○
	b034	Thermistor selection	0(Disable), 1(PTC), 2(NTC)	0	○
	b035	Thermistor error level	0~9999[Ω]	3000	○
	b036	Thermistor adjustment	0.0~999.9	105.0	○
Communication setting	b037	Data command selection	0(OPERATOR), 1(RS485), 2(OPT1), 3(OPT2), 4(RS232)	0	×
	b038	Communicating transmission speed	0(2400BPS), 1(4800BPS), 2(9600BPS), 3(19200BPS), 4(38400BPS)	2	×
	b039	Communication code	1~32	1	○
	b040	Communication bit	7(BIT), 8(BIT)	8	○
	b041	Communication parity	0(NO Parity), 1(Even Parity), 2(Odd Parity)	0	○
	b042	Communication stop bit	1(1Bit), 2(2it)	1	○

## Intelligent input terminal setting (I-group)

Main function	Code	Function name	Setting range	Initial Data	Change mode on run
<b>Terminal Input Functions &amp; Contacts</b>					
Basic monitor	I001	Intelligent input 1 setting	Intelligent input setting reference	17	○
	I002	Intelligent input 2 setting		16	○
	I003	Intelligent input 3 setting		6	○
	I004	Intelligent input 4 setting		11	○
	I005	Intelligent input 5 setting		9	○
	I006	Intelligent input 6 setting		3	○
	I007	Intelligent input 7 setting		2	○
	I008	Intelligent input 8 setting		1	○
Intelligent input selection	I009	Intelligent input 1 selection	Intelligent input setting(a/b contact setting) 0 (N.O.), 1(N.C.)	0	○
	I010	Intelligent input 2 selection		0	○
	I011	Intelligent input 3 selection		0	○
	I012	Intelligent input 4 selection		0	○
	I013	Intelligent input 5 selection		0	○
	I014	Intelligent input 6 selection		0	○
	I015	Intelligent input 7 selection		0	○
	I016	Intelligent input 8 selection		0	○
FW setting	I017	FW input terminal selection	0 (N.O.), 1(N.C.)	0	○
<b>Analog Command Setting</b>					
Terminal O setting	I018	O input span calibration	0~9999	Factory setting	○
	I019	O input zero calibration	0~9999	Factory setting	○
	I020	O start frequency	0~99.99/100.0~400.0[Hz]	0.00	○
	I021	O end frequency	0~99.99/100.0~400.0[Hz]	0.00	○
	I022	O start voltage	0~100[%]	0	○
	I023	O end voltage	0~100[%]	100	○
	I024	O start selection	0(EXT. FREQ.), 1(ZERO HZ)	1	○
Terminal OI setting	I025	OI input span calibration	0~9999	Factory setting	○
	I026	OI input zero calibration	0~9999	Factory setting	○
	I027	OI start frequency	0~99.99/100.0~400.0[Hz]	0.00	○
	I028	OI end frequency	0~99.99/100.0~400.0[Hz]	0.00	○
	I029	OI start voltage	0~100[%]	0	○
	I030	OI end voltage	0~100[%]	100	○
	I031	OI start selection	0(EXT. FREQ.), 1(ZERO HZ)	1	○
Terminal O2 setting	I032	O2 input span calibration	0~9999	Factory setting	○
	I033	O2 input zero calibration	0~9999	Factory setting	○
	I034	O2 start frequency	0.0~99.9/100~400[Hz]	0.0	○
	I035	O2 end frequency	0.0~99.9/100~400[Hz]	0.0	○
	I036	O2 start voltage	-100~100[%]	-100	○
	I037	O2 end voltage	-100~100[%]	100	○
	I038	O2 start selection	0(SINGLE), 1(AUX. NO REV), 2(AUX. REV)	0	×
Other useful functions	I046	Analog input filter factor	1~30	8	○
	I047	Software lock mode selection	0(All parameters except I047 are locked when SFT is on) 1(All parameters except I047, F001 are locked when SFT is on) 2(All parameters except I047, F001 and User group are locked when SFT is on) 3(All parameters except I047 are locked) 4(All parameters except I047, F001 are locked) 5(All parameters except I047, F001 and User group are locked)	1	○
	I048	Up/Down Selection	0(Data conservation Dis), 1(Data conservation En)	0	○
	I049	AT terminal selection	0(O/OI), 1(O/O2)	0	○
	Reset	I050	Reset selection	0(TRIP (On)), 1(TRIP (Off)), 2(ONLYTRIP (On))	0
I051		Reset frequency matching selection	0(Zero HZ), 1(Frequency matching)	0	○

# FUNCTION LIST

## Intelligent output terminal setting (o-group)

Main function	Code	Function name	Setting range	Initial Data	Change mode on run
Terminal Output Functions & Contacts					
Intelligent output setting	o001	Intelligent output 1 setting	Intelligent output setting reference	1	○
	o002	Intelligent output 2 setting		0	○
	o003	Intelligent output 3 setting		3	○
	o004	Intelligent output 4 setting		7	○
Intelligent output selection	o005	Intelligent output 1 selection	Intelligent output contact setting (0 : N.O., 1 : N.C.)	0	○
	o006	Intelligent output 2 selection		0	○
	o007	Intelligent output 3 selection		0	○
	o008	Intelligent output 4 selection		0	○
FM setting	o009	FM output selection	0(FREQ_OUT), 1(CURR_OUT), 2(TORQ_OUT), 3(DFREQ_OUT), 4(VOL_OUT), 5(POW_IN), 6(LOAD RATE), 7(FREQ_LAD)	0	○
	o010	FM offset	-3.00~10.00	-3.00	○
	o011	FM adjustment	0.0~255.0	80.0	○
AM setting	o012	AM output selection	0(FREQ_OUT), 1(CURR_OUT), 2(TORQ_OUT), 3(VOL_OUT), 4(POW_IN), 5(LOAD RATE), 6(FREQ_LAD)	0	○
	o013	AM offset	0.00~10.00	0.96	○
	o014	AM adjustment	0.0~255.0	100.0	○
AMI setting	o015	AMI output selection	0(FREQ_OUT), 1(CURR_OUT), 2(TORQ_OUT), 3(VOL_OUT), 4(POW_IN), 5(LOAD RATE), 6(FREQ_LAD)	0	○
	o016	AMI offset	0.00~20.00	4.00	○
	o017	AMI adjustment	0.0~255.0	100.0	○
Frequency arrival setting	o018	Frequency arrival setting for acceleration	0~99.99/100.0~400.0[Hz]	0.00	○
	o019	Frequency arrival setting for deceleration	0~99.99/100.0~400.0[Hz]	0.00	○
	o020	Frequency arrival setting for acceleration 2	0~99.99/100.0~400.0[Hz]	0.00	○
	o021	Frequency arrival setting for deceleration 2	0~99.99/100.0~400.0[Hz]	0.00	○
Over-torque level setting	o022	Over-torque level 1	0~200[%]	100	○
	o023	Over-torque level 2	0~200[%]	100	○
	o024	Over-torque level 3	0~200[%]	100	○
	o025	Over-torque level 4	0~200[%]	100	○
Other useful functions	o026	Overload advance notice level 1	Rated current x 0.0~2.0[times]	1.0	○
	o027	Overload advance notice level 2	Rated current x 0.0~2.0[times]	1.0	○
	o028	RUN/ON time-over setting	0~9999	0	○
	o029	PID deviation setting level	0.0~100.0[%]	3.0	○
	o030	Zero speed detection level setting	0.00~99.99[Hz]	0.00	○
Relay output setting	o031	AL relay output definition	Refer to the intelligent output setting	5	○
	o032	RN relay output definition		0	○
	o033	AL relay output selection	Intelligent output contactor setting	0	○
	o034	RN relay output selection	0 : N.O., 1 : N.C	0	○

## Advanced control function setting (C-group)

Main function	Code	Function name	Setting range	Initial Data	Change mode on run
Torque boost setting	C002	V/f stability constant	0.0~300.0[%]	100	○
	C003	Torque boost selection	0(Manual), 1(Automatic)	0	×
	C203	Torque boost selection, 2nd motor	0(Manual), 1(Automatic)	0	×
	C004	Manual torque boost value	0.0~20.0[%]	1.0	○
	C204	Manual torque boost value, 2nd motor	0.0~20.0[%]	1.0	○
	C005	Manual torque boost break point	0.0~50.0[%]	5.0	○
	C205	Manual torque point boost frequency, 2nd motor	0.0~50.0[%]	5.0	○
Torque limit setting	C006	Torque limit selection	0(User mode), 1(TER. OPR) 2(Analog IN), 3(OPT1), 4(OPT2)	0	○
	C007	Torque limit 1	0~200[%]	200	○
	C008	Torque limit 2	0~200[%]	200	○
	C009	Torque limit 3	0~200[%]	200	○
	C010	Torque limit 4	0~200[%]	200	○
	C011	Torque LAD Stop selection	0(Disable), 1(Enable)	0	○
	C012	Braking control function selection	0(Disable), 1(Enable)	0	○
External brake setting	C013	Waiting time for braking release confirmation	0.00~5.00[sec]	0.00	○
	C014	Waiting time for acceleration	0.00~5.00[sec]	0.00	○
	C015	Waiting time for stop	0.00~5.00[sec]	0.00	○
	C016	Waiting time for signal conformation	0.00~5.00[sec]	0.00	○
	C017	Releasing frequency	0~99.99/100.0~400.0[Hz]	0.00	○
	C018	Releasing current	Rated current x (0.0~2.0)[times]	1.0	○
	C019	BRD selection	0(INVALID), 1(VAL. Exclude ST), 2(VAL. Include ST)	0	○
BRD setting	C020	BRD ON level	330~380/660~760	360(720)	○
	C021	BRD using ratio	0.0~100%	0.0	○
	C022	PID selection	0(Disable), 1(Enable), 2(Reverse Enable)	0	○
PID driving	C023	PID-P gain	0.0~5.0	2.0	○
	C024	PID-I gain	0~3600[sec]	1	○
	C025	PID-D gain	0.0~100.0[sec]	0.0	○
	C026	PID-Feedback gain	0.00~99.99[times]	1.00	○
	C027	PID Feedback selection	0(Current), 1(Voltage)	0	○

HYUNDAI INVERTER  
N700 Series

# FUNCTION LIST

## Motor constant setting (H-group)

Main function	Code	Function name	Setting range	Initial Data	Change mode on run
Auto tuning setting	H001	Auto tuning selection	0(INVALID),1(VVALID NOT ROT.),2(VVALID IN ROT.)	0	×
	H002	Motor constant selection	0(MOTOR DATA),1(AT DATA),2(AT ONLINE DATA)	1	×
	H202	Motor constant selection, 2nd motor	0(MOTOR DATA),1(AT DATA),2(AT ONLINE DATA)	1	×
Manual motor constant setting	H003	1st motor constant R1	0.000~9.999[Ω]	R1std	×
	H203	2nd motor constant R1	0.000~9.999[Ω]	R1std	×
	H004	1st motor constant R2	0.000~9.999[Ω]	R2std	×
	H204	2nd motor constant R2	0.000~9.999[Ω]	R2std	×
	H005	1st motor constant leakage inductance(LI)	0.00~99.99[mH]	Llstd	×
	H205	2nd motor constant leakage inductance(LI)	0.00~99.99[mH]	Llstd	×
	H006	1st motor constant lo	0.00~99.99/100.0~999.9[A]	lstd	×
	H206	2nd motor constant lo	0.00~99.99/100.0~999.9[A]	lstd	×
	H007	1st motor constant J	0.00~99.99/100.0~655.3[kg·m <sup>2</sup> ]	Jstd	×
	H207	2nd motor constant J	0.00~99.99/100.0~655.3[kg·m <sup>2</sup> ]	Jstd	×
Autotuning motor constant	H008	1st motor constant L	0.00~99.99/100.0~999.9[mH]	Lstd	×
	H208	2nd motor constant L	0.00~99.99/100.0~999.9[mH]	Lstd	×
	H009	1st motor constant R1 (Autotuning data)	0.000~9.999[Ω]	R1std	×
	H209	2nd motor constant R1 (Autotuning data)	0.000~9.999[Ω]	R1std	×
	H010	1st motor constant R2 (Autotuning data)	0.000~9.999[Ω]	R2std	×
	H210	2nd motor constant R2 (Autotuning data)	0.000~9.999[Ω]	R2std	×
	H011	1st motor constant leakage inductance(LI) (Autotuning data)	0.00~99.99[mH]	Llstd	×
	H211	2nd motor constant leakage inductance(LI) (Autotuning data)	0.00~99.99[mH]	Llstd	×
	H012	1st motor constant lo (Autotuning data)	0.00~99.99/100.0~999.9[A]	lstd	×
	H212	2nd motor constant lo (Autotuning data)	0.00~99.99/100.0~999.9[A]	lstd	×
	H013	1st motor constant J (Autotuning data)	0.00~99.99/100.0~655.3[kg·m <sup>2</sup> ]	Jstd	×
	H213	2nd motor constant J (Autotuning data)	0.00~99.99/100.0~655.3[kg·m <sup>2</sup> ]	Jstd	×
	H014	1st motor constant L (Autotuning data)	0.00~99.99/100.0~999.9[mH]	Lstd	×
	H214	2nd motor constant L (Autotuning data)	0.00~99.99/100.0~999.9[mH]	Lstd	×

## Option function setting (P-group)

Main function	Code	Function name	Setting range	Initial Data	Change mode on run
Option error	P001	Option 1 operation selection on error	0(TRIP), 1(RUN)	0	○
	P002	Option 2 operation selection on error	0(TRIP), 1(RUN)	0	○
Encoder feedback	P003	Feed-back option selection	0(INVALID), 1(VVALID)	0	×
	P004	Control mode selection	0(ASR), 1(APR)	0	×
	P005	Encoder pulse number setting	128.~9999./1000~6500(10000~65000) [PPR]	1024	×
	P006	Pulse train input mode selection	0(MODE 0), 1(MODE 1)	0	×
Orientation	P007	Orientation stop position setting	0~4095	0	○
	P008	Orientation speed setting	0.00~99.99/100.0~120.0[Hz]	0.00	○
	P009	Orientation direction setting	0(FORWARD), 1(REVERSE)	0	×
	P010	Orientation completion range setting	0~9999	5	○
	P011	Orientation completion delay time setting	0.00~9.99[sec]	0.00	○
Electronic gear	P012	Electronic gear position selection	0(FEEDBACK), 1(REFERENCE)	0	○
	P013	Electronic gear numerator of ratio setting	0~9999	1024	○
	P014	Electronic gear denominator of ratio setting	0~9999	1024	○
Position control	P015	Position control feed-forward gain setting	0.00~99.99/100.0~655.3	0.00	○
	P016	Position control loop gain setting	0.00~99.99	0.50	○
Other useful function	P017	Compensation of secondary resistor selection	0(INVALID), 1(VVALID)	0	○
	P018	Over-speed detect level setting	0.00~99.99/100.0~150.0[%]	135.0	○
	P019	Speed-error over detect level setting	0.00~99.99/100.0~120.0[Hz]	0.00	○
	P020	Digital input option input mode selection(Acc/Dec)	0(OPE), 1(OPT1), 2(OPT2)	0	○
	P021	Stop position setting for orientation input mode selection	0(OPE), 1(OPT1), 2(OPT2)	0	×

## Main Circuit Terminals

### Explanation of main circuit terminals

Symbol	Terminal Name	Explanation of contents
R, S, T (L1, L2, L3)	Main power	Connect alternating power supply. When using regenerative converter and RG series, don't connect.
U, V, W (T1, T2, T3)	Inverter output	Connect three-phase motor.
PD, P (+1, +)	DC reactor	Remove the short bar between PD and P, connect optional Power factor reactor (DCL-XX).
P, RB (+, RB)	External braking resistor	Connect optional External braking resistor. (Please install the optional External braking resistor for 5.5~22Kw model.)
P, N (+, -)	External regenerative braking unit	Connect optional External regenerative braking unit.
G	Inverter earth terminals	Grounding terminal.

### Main circuit terminal arrangement

Wiring of terminals	Corresponding type
	<b>N700</b> - 055LF / 075LF / 110LF <b>N700</b> - 055HF / 075HF / 110HF - Screw size : M5
	<b>N700</b> - 150LF / 185LF / 150HF / 185HF / 220HF - Screw size : M6
	<b>N700</b> - 220LF - Screw size : M8
	<b>N700</b> - 300LF / 370LF / 450LF - 300HF / 370HF / 450HF / 550HF / 750HF / 900HF - Screw size : M8  <b>N700</b> - 550LF <b>N700</b> - 1100HF / 1320HF - Screw size : M10

## Control circuit terminals

### Control Terminal Arrangement

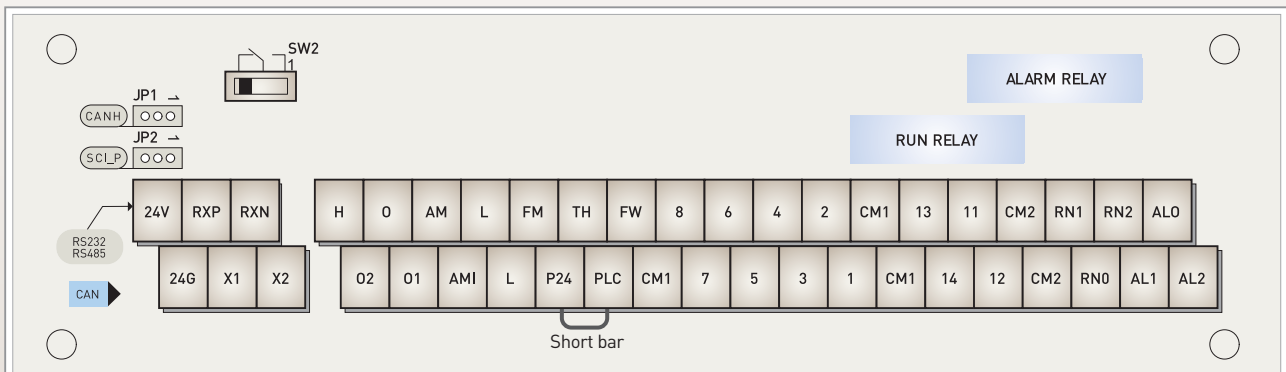

## Explanation of control circuit terminals

Type		Symbol	Terminal Name	Explanation of contents		
Analog	Power Source	L	Analog power common	It is common terminal of frequency command signal (O, O2, OI) and analogue output(AM, AMI). Do not connect to ground.		
		H	Frequency power	It is the DC+10V power for terminals.	Permissible load current 20mA	
	Frequency setting	O	Frequency command power terminal (voltage)	When inputting DC 0~10V, the maximum frequency goes with 10V.	Input Impedance 14.4k ohm Permissible maximum voltage DC -3~+12V	
		O2	Frequency command support (voltage)	When inputting DC 0~±10V, this signal is added to frequency command of O or OI terminal.	Input Impedance 13k ohm Permissible maximum voltage DC 0~±12V	
		OI	Frequency command Terminal (current)	When inputting 4~20mA, 20mA is maximum frequency. When only 'AT' terminal is ON, this input signal is effective.	Input Impedance 180 ohm Permissible maximum current 24mA	
	Monitor	AM	Analog monitor (voltage)	DC 0~10V output voltage, 4~20mA output current :	Permissible maximum current 2mA	
		AMI	Analog monitor (current)	Output one selected from monitor item,output frequency,output current, torque, output voltage,input electric power,electric thermal rate,LAD frequency	Permissible output less than Impedance 250 ohm	
Digital (connection)	Power Source	FM	Digital monitor (voltage)	DC 0~10 voltage output (PWM output mode) : Output the output frequency with digital besides above monitor.	Permissible maximum current 1.2mA Maximum frequency 3.6kHz	
		P24	Interface power	It is DC24V power for connection input signal. When selecting source logic, contact input is common.	Permissible maximum output current 100mA	
	CM1	Interface power common	The common terminal is FW terminal, 1-8 terminal, TH terminal, FM terminal. Do not connect to earth ground.			
Digital (connection)	Input signal	OP.	FW	Forward command	About FW signal, ON is Forward and OFF is stop command.	
		Operation/ Function Selection etc	1(RS) 2(AT) 3(JOG) 4(FRS) 5(2CH) 6(CF2) 7(CF1) 8(REV)	Input intelligent	Select 8 functions from 39 functions, and divide between 1 terminal and 8 terminals. REV(Reverse), CF1~CF4(Multi-speed bit 1~4), JOG(jogging), DB(External dc braking), SET2(2nd control), 2CH(2nd acceleration), 3CH(3rd acceleration), FRS(free-run stop), EXT(external trip), USP(USP function), CS(Commercial power source switching), SFT(software lock), AT(analog input change),RS(reset), STA(3wire run), STP(3wire keep), F/R(3wire direction selection), PID(PID selection valid/invalid), PID_C(PID integrating reset), UP(remote control, up function), DOWN(remote control down function), UDC(remote control data clear), OPE(compulsion operation), OLR(Overload restriction change), TL(torque limit exist or no), TRQ1(torque limit change1), TRQ2(torque limit change2), PPI, BOK(brake confirmation), ORT(orientation), LAC(LAD cancel), PCLR(position deviation clear), STAT(90 degrees the phase difference permission), XT1, XT2, XT3 (Multi-step acceleration/deceleration time 1~3)	When use external electric power source: (The voltage between input and PLC) more than DC 18V Input interface: (Between input and PLC) 4.7Ω Permissible maximum voltage: (The voltage between input and PLC) 27V
	PLC		Intelligent input common	Change sink type and source type by short bar on control terminals. P24-PLC : Sink type CM1-PLC:Source type		
	Input signal	Condition/ Alarm	11(FA1) 12(RUN) 13(OL) 14(OTQ)	Output intelligent	Select 5 functions from inverter state s 24functions, and configure them at terminal11~14/ RUN(Signal during run), FA1(Frequency arrival type 1 signal), FA2(Frequency arrival type 2 signal), OL(Overload advance notice signal), OD(Output deviation for PID control), ALM(Alarm signal), FA3(Arrival signal for only setting frequency), OTQ(Over torque), IP(Instantaneous stop signal), UV(Under voltage signal), TRQ(Torque limit), RNT(RUN time over), ONT(ON time over), THM(Thermal caution), BRK(Brake opening), BER(Brake error), ZS(Zero speed detect signal), DSE(Speed deviation excessive), POK(Positioning completion), FA4(Arrival signal for over setting frequency2), FA5(Arrival signal for only setting frequency2), OL2(Overload advance notice signal2), IPALM(Instantaneous power failure alarm signal), UVALM(Under voltage alarm signal)	Permissible maximum voltage DC27V Current 50mA(0.2W) Between 11~14terminal and CM2: Under 4V when ON.
			CM2	Output intelligent common	Common terminal for intelligent output 11~14 terminal. External electric power source common terminal.	
		AL0 RN0	AL Relay common RN Relay common	AL0 : AL Relay common contact RN0 : RN Relay common contact	Permissible maximum AL1-AL0, RN1-RN0: AC250V, 2A(Resister), 0.2A(Induction)	
		AL1 AL2/ RN1 RN2	Alarm Relay output terminal RUN Relay output terminal	Assign output function. Output is C-contact.	AL2-AL0, RN2-RN0: AC250V, 2A(Resister), 0.2A(Induction)	
	Analogue	Sensor	TH	Thermistor input terminal	When a thermistor is connected to terminals TH and CM1,the inverter checks for over-temperature and will cause trip event and turn off output to motor.	Permissible minimum Thermistor Power 100mW

\* ( ) is the factory initial setting value.

Terminal Connecting Diagram (sink type)

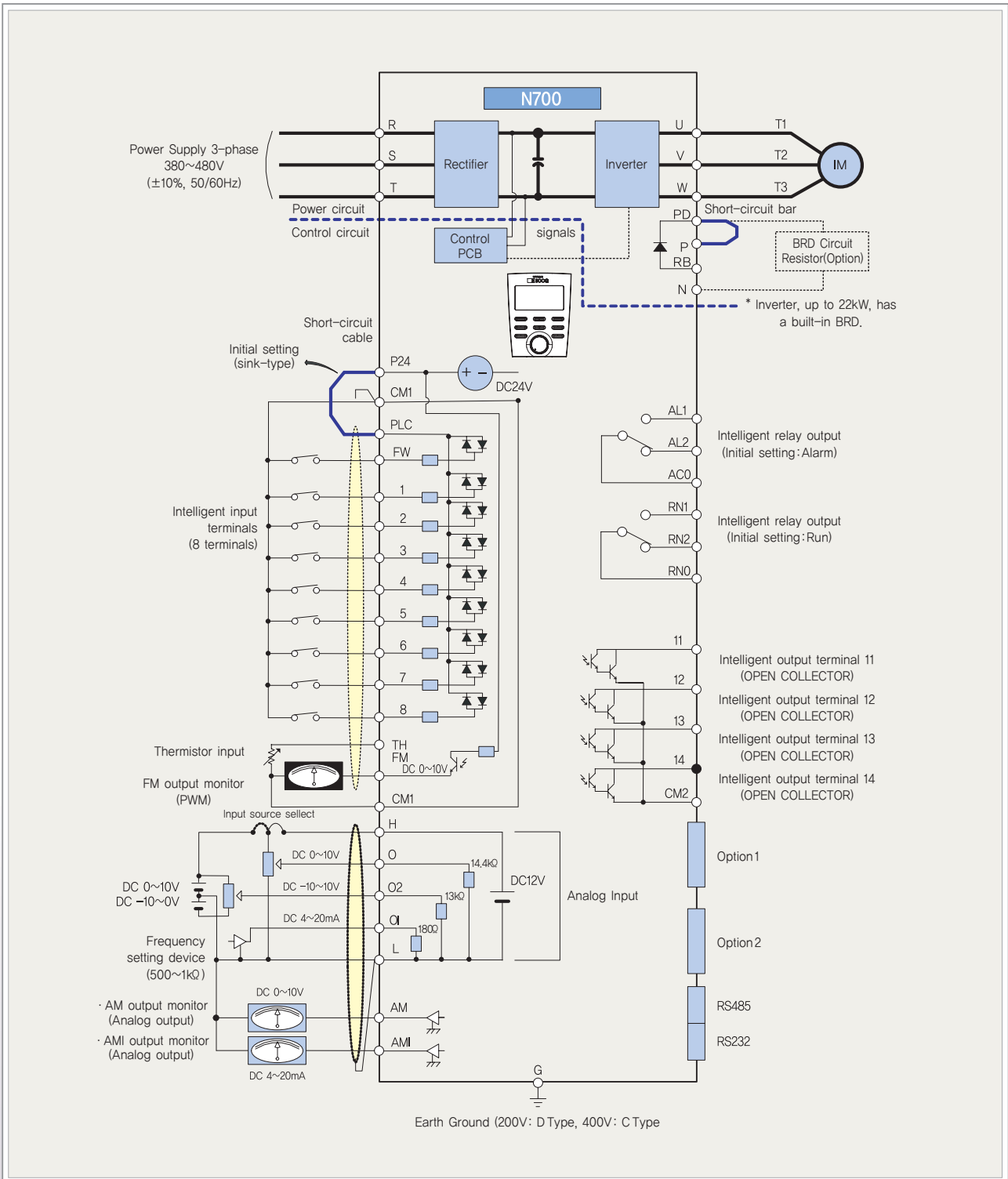

Terminal Name	FW, PLC, 8, 7, 6, 5, 4, 3, 2, 1, FM, THM	H, O, O2, OI, AM, AMI	14, 13, 12, 11
Common	CM1	L	CM2

\* Common of each terminal is different from each other.

## Connection with Input Terminals

### Using internal power source of the inverter

■ Sink type logic

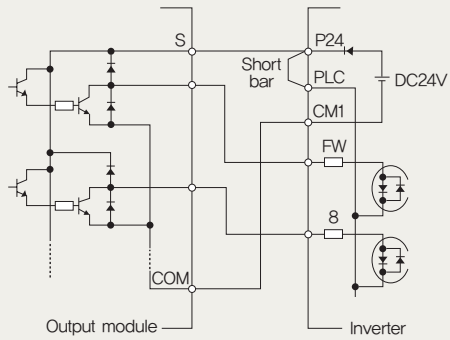

■ Source type logic

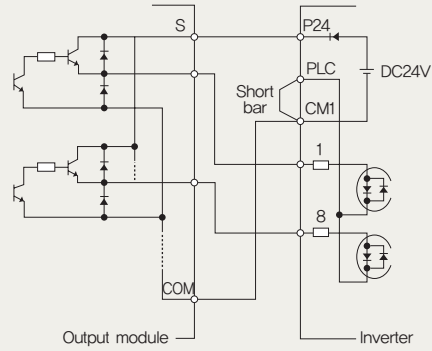

### Using external power source

■ Sink type logic

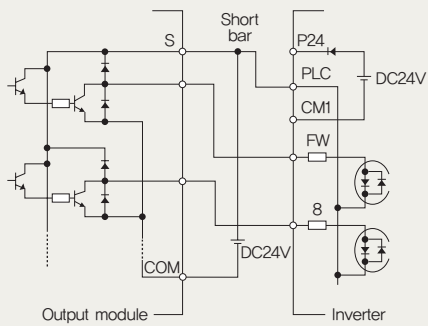

■ Source type logic

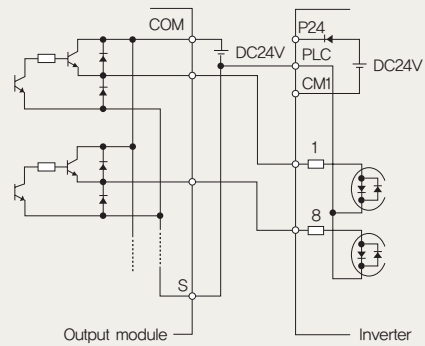

※ Be sure to turn on the inverters after turning on the PLC and its external power source to prevent the parameters in the inverter from being modified.

## Connection with Output Terminals

■ Sink type logic

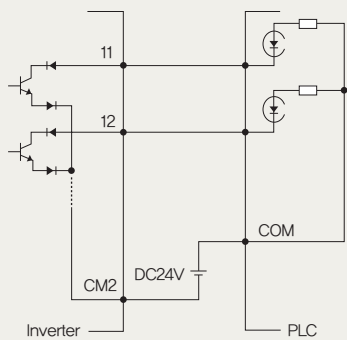

■ Source type logic

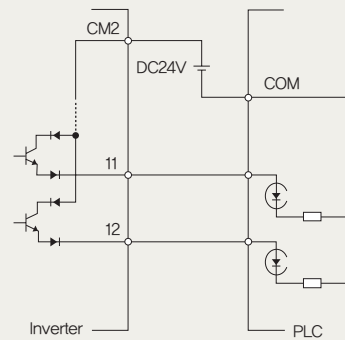

Error Code

Name	Function name	Display on digital operator	Display on remote operator	
Over-current protection	The inverter output was short-circuited, or the motor shaft is locked or has a heavy load. These conditions cause excessive current for the inverter, so the inverter output is turned off.	While at constant speed	E01	OC.CON
		During acceleration	E02	OC.ACC
		During deceleration	E03	OC.DEC
		Others	E04	OC.ETC
Overload protection (Note1)	When a motor overload is detected by the electronic thermal function, the inverter trips and turns off its output. When the regenerative braking resistor exceeds the usage time allowance or an over voltage caused by the stop of the BRD function is detected, the inverter trips and turns off its output. When the DC bus voltage exceeds a threshold, due to regenerative energy from the motor, the inverter trips and turns off its output. A decrease of internal DC bus voltage below a threshold results in a control circuit fault. This condition can also generate excessive motor heat or cause low torque. The inverter trips and turns off its output.		E05	OL.MOT
Braking resistor overload protection			E06	OL.DBR
Over-voltage protection			E07	OV.DC
Under-voltage protection			E09	UV.DC
External trip	When the external equipment or unit has an error, the inverter receives the corresponding signed and cut off the output. An error occurs when power is cycled while the inverter is in RUN mode if the Unattended Start Protection (USP) is enabled. The inverter trips and does not go into RUN mode until the error is cleared.		E12	EXT.ERR
USP error			E13	USP.ERR
Ground fault protection	The inverter is protected by the detection of ground faults between the inverter output and the motor during power-up tests. This feature protects the inverter only. When power is cut for more than 15ms, the inverter trips and turns off its output. If power failure continues, the error will be cleared. The inverter restarts if it is in RUN mode when power is cycled.		E14	GND.FLT
Instantaneous power failure protection			E16	IPF.ERR
Inverter thermal trip	When the inverter internal temperature is higher than the specified value, the thermal sensor in the inverter module detects the higher temperature of the power devices and trips, turning off the inverter output.		E17	OT.ERR
Open-phase protection	When R phase is opened, inverter turns off its output.		E20	R PH.ERR
	When S phase is opened, inverter turns off its output.		E21	S PH.ERR
	When T phase is opened, inverter turns off its output.		E22	T PH.ERR
Thermistor error	When the thermistor inside the motor detects temperature higher than the specified value, the inverter trips and turns off its output. The inverter turns off its output when it can not detect whether the braking is ON or OFF within waiting time set at b024 after it has released the brake.(When braking is enabled at b120)		E24	THMIS.ERR
Braking error			E25	BRK.ERR
Communication error	An error between operator and inverter has been detected.		E26	COMM.ERR
Overtime of reset input	An error is displayed when input time of the reset signal exceeds the setting time 5seconds		E27	RESET.ERR
IGBT protection	When an instantaneous over-current has occurred, the inverter trips and turns off its output to protect the main devices. - output phase U.		E28	UIGBT.ERR
	When an instantaneous over-current has occurred, the inverter trips and turns off its output to protect the main devices. - output phase V.		E29	VIGBT.ERR
	When an instantaneous over-current has occurred, the inverter trips and turns off its output to protect the main devices. - output phase W.		E30	WIGBT.ERR
Option error	An error has been detected in an option PCB 1,2. You can refer to the details of option PCB's instruction manual		E31	OPT.ERR
Over speed error	When the motor rotation speed exceeds the specified value, the inverter occur an error.		E32	RESVD

Note1) After a trip occurs and 10 second pass, restart with reset operation.

Error Status Display

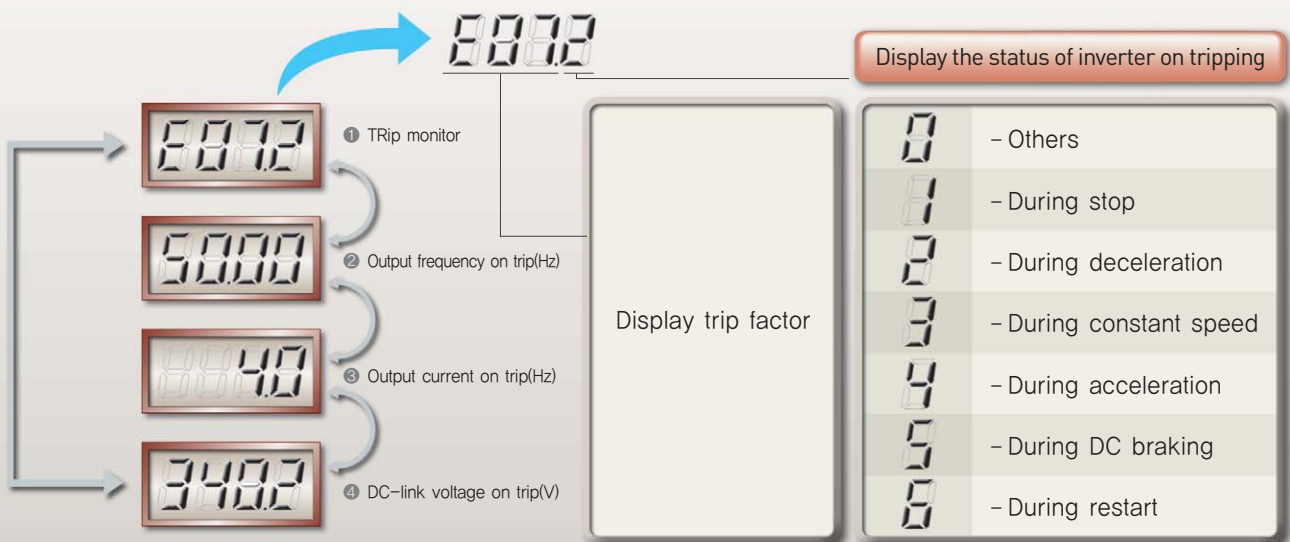

## Common applicable tools

Class	Motor Output kW(HP)	Inverter model	Power lines R,S,T,U,V, W,P,PD,N(mm <sup>2</sup> )	External resistor between P and RB(mm <sup>2</sup> )	Screw size of Terminal	Torque (N · m)	Applicable Tools		
							Leak breaker (MCCB)		Electromagnetic Controller(MC)
200V class	5.5(7.5)	N700-055LF	More than 6	6	M5	3.0	HBS60N	50A	HiMC32
	7.5(10)	N700-075LF	More than 10	6	M5	3.0	HBS60N	50A	HiMC32
	11(15)	N700-110LF	More than 16	6	M5	3.0	HBS100N	75A	HiMC50
	15(20)	N700-150LF	More than 25	16	M6	4.5	HBS100N	100A	HiMC65
	18.5(25)	N700-185LF	More than 30	16	M6	4.5	HBS225N	150A	HiMC80
	22(30)	N700-220LF	More than 35	16	M8	6.0	HBS225N	150A	HiMC110
	30(40)	N700-300LF	More than 25X2	-	M8	6.0	HBS225N	200A	HiMC130
	37(50)	N700-370LF	More than 35X2	-	M8	6.0	HBS225N	225A	HiMC150
	45(60)	N700-450LF	More than 35X2	-	M8	6.0	HBS400N	225A	HiMC220
400V class	55(75)	N700-550LF	More than 70X2	-	M10	10.0	HBS400N	300A	HiMC220
	5.5(7.5)	N700-055HF	More than 4	4	M5	3.0	HBS30N	30A	HiMC18
	7.5(10)	N700-075HF	More than 4	4	M5	3.0	HBS30N	30A	HiMC18
	11(15)	N700-110HF	More than 6	6	M5	3.0	HBS60N	50A	HiMC32
	15(20)	N700-150HF	More than 10	10	M6	4.5	HBS100N	50A	HiMC40
	18.5(25)	N700-185HF	More than 16	10	M6	4.5	HBS100N	75A	HiMC40
	22(30)	N700-220HF	More than 25	10	M6	4.5	HBS100N	75A	HiMC50
	30(40)	N700-300HF	More than 25	-	M8	6.0	HBS100N	100A	HiMC65
	37(50)	N700-370HF	More than 35	-	M8	6.0	HBS225N	100A	HiMC80
	45(60)	N700-450HF	More than 35	-	M8	6.0	HBS225N	150A	HiMC110
	55(75)	N700-550HF	More than 70	-	M8	6.0	HBS225N	175A	HiMC130
	75(100)	N700-750HF	More than 35X2	-	M8	6.0	HBS400	225A	HiMC180
	90(125)	N700-900HF	More than 35X2	-	M8	6.0	HBS400	225A	HiMC220
	110(150)	N700-1100HF	More than 50X2	-	M10	10.0	HBS400	350A	HiMC260
132(200)	N700-1320HF	More than 80X2	-	M10	10.0	HBS400	350A	HiMC300	

\* Field wiring connection must be made by a UL listed and C-UL certified closed-loop terminal connector sized for the wire gauge involved. Connector must be fixed using the crimp tool specified by the connector manufacturer.

\* Be sure to use bigger wires for power lines if the distance exceeds 20m.



**HYUNDAI INVERTER  
N700 Series**

## Wiring And Options

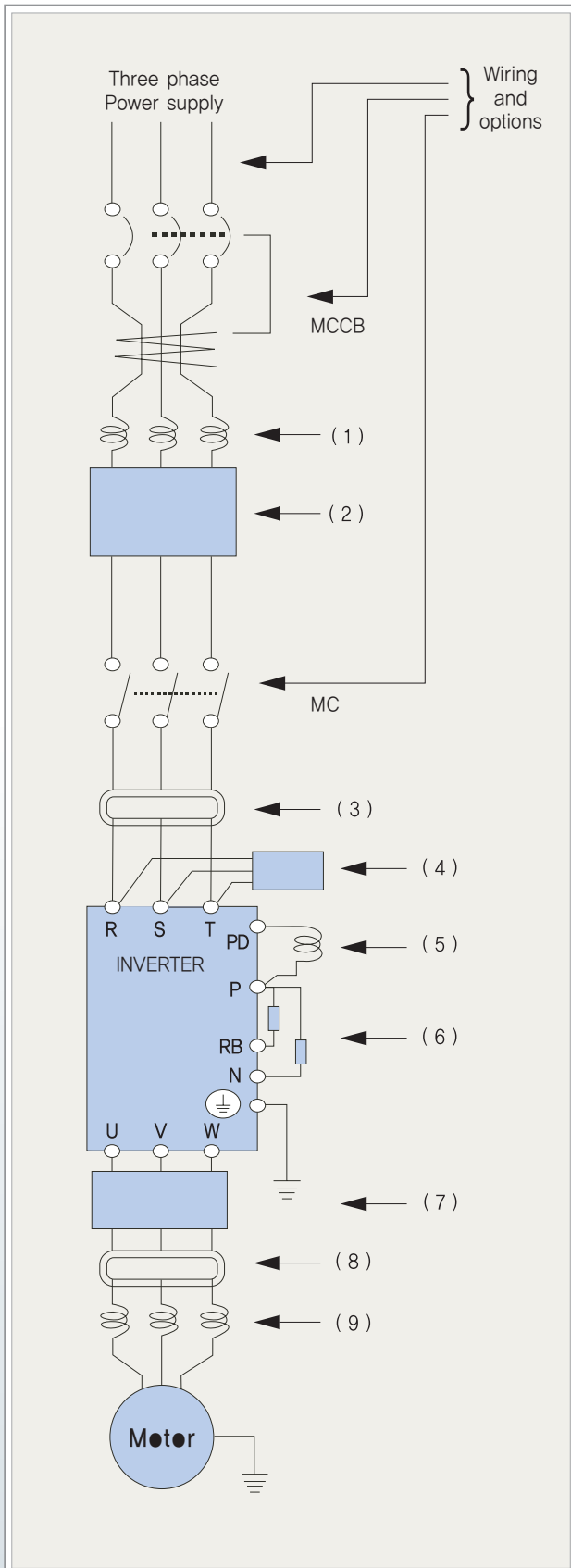

Separate by the sum(wiring distance from inverter to power supply, from inverter to motor for the sensitive current of leak breaker (ELB).

Wiring distance	Sensitive Current(mA)
100m and less	30
300m and less	100
600m and less	200

Note 1) When using CV line and wiring by rigid metal conduit, leak flows.

Note 2) IV line is high dielectric constant. So the current increase 8 times.

Therefore, use the sensitive current 8 times as large as that of the left list. And if the distance of wire is over 100m, use CV line.

Name	Function
(1) Input-side AC reactor (harmonic control, electrical coordination, power-factor improvement)	This is useful in suppressing harmonics induced on the power supply lines, or when the main power voltage imbalance exceeds 3%(and power source capacity is more than 500kVA), or to smooth out line fluctuations. It also improves the power factor.
(2) Radio noise filter (zero-phase reactor)	Electrical noise interference may occur on nearby equipment such as a radio receiver. This magnetic choke filter helps reduce radiated noise (can also be used on output).
(3) EMI filter	Reduces the conducted noise on the power supply wiring generated by the inverter. Connect to the inverter input side.
(4) Radio noise filter (capacitive filter)	This capacitive filter reduces radiated noise from the main power wires in the inverter input side.
(5) DC link choke	Suppresses harmonics generated by the inverter.
(6) Breaking resistor Regenerative breaking unit	This is useful for increasing the inverter's control torque for high duty-cycle (on-off) applications, and improving the decelerating capability.
(7) Output-side noise filter	Reduces radiated noise from wiring in the inverter output side. It reduces wave fault to radio and TV, and it is used for preventing malfunction of sensor and measuring instruments.
(8) Radio noise filter (zero-phase reactor)	Electrical noise interference may occur on nearby equipment such as a radio receiver. This magnetic choke filter helps reduce radiated noise (can also be used on input)
(9) Output-side AC reactor (To reduce the vibration and to prevent thermal relay misapplication)	This reactor reduces the vibration in the motor caused by the inverter's switching waveforms, by smoothing the waveforms to approximate commercial power quality. It is also useful when wiring from the inverter to the motor is more than 10m in length, to reduce harmonics.
LCR filter	Sine-wave shaping filter for the output side.

## 입 · 출력 교류리액터

### ■ Dimension

※ ( )내 단자 번호는 역률 개선용 교류리액터의 경우임

### ■ Connecting Diagram

### Dimension of Input-side AC Reactor

#### ACL-L I-2.5

L: 3상 200V  
H: 3상 400V

인버터 출력 용량(kVA)

- 고조파 억제
- 전원 협조
- 역률 개선용

### Dimension of Output-side AC Reactor

#### ACL-L-2.5

L: 3상 200V  
H: 3상 400V

모터 용량(kW)

- 진동 저감
- 써멀 릴레이
- 오작동 방지용

### 역률 개선용 교류리액터의 치수

전압	기종	인버터 용량 (kW)	취부 치수(mm)						규격 (K)	중량 (kg)	외형도
			A	C	H	X	T	J			
200V	ACL-LI-1.5	0.75	110	80	110	40	52	6	4	1.85	1
	ACL-LI-2.5	1.5	130	90	130	50	67	6	4	3.0	1
	ACL-LI-3.5	2.2	130	95	130	50	70	6	4	3.4	1
	ACL-LI-5.5	3.7	130	100	130	50	72	6	4	3.9	1
	ACL-LI-7.5	5.5	130	115	130	50	90	6	4	5.2	1
	ACL-LI-11	7.5	180	120	190	60	80	6	5	8.6	1
	ACL-LI-15	11	180	120	190	100	80	6	6.7	10.0	2
	ACL-LI-22	15	220	130	200	90	90	6	8	11.0	1
	ACL-LI-33	18.5/22	220	130	200	125	90	6	8	15.0	1
	ACL-LI-40	30	270	130	250	100	90	6	8	15.0	2
	ACL-LI-50	37	270	130	250	100	90	7	8.3	16.0	2
	ACL-LI-60	45	270	135	250	100	95	7	8.3	16.5	2
400V	ACL-LI-70	55	270	130	250	125	112	7	8.3	24.0	2
	ACL-HI-5.5	3.7	130	90	130	50	75	6	4	3.9	1
	ACL-HI-7.5	5.5	130	105	130	50	90	6	4	5.1	1
	ACL-HI-11	7.5	160	110	160	60	95	6	4	8.7	1
	ACL-HI-15	11	180	100	190	100	80	6	4	10	2
	ACL-HI-22	15	180	110	190	100	80	6	5	10	1
	ACL-HI-33	18.5/22	180	140	190	100	100	6	5	12	1
	ACL-HI-40	30	270	120	210	100	100	7	6.7	14	2
	ACL-HI-50	37	270	120	250	100	90	7	8.3	15.5	2
	ACL-HI-60	45	270	125	250	100	95	7	8.3	16	2
	ACL-HI-70	55	270	130	250	125	112	7	8.3	23.5	2
	ACL-HI-100	75	270	140	250	125	112	7	10.3	26.5	2
ACL-HI-120	90	320	150	300	125	125	7	10.3	31	2	
ACL-HI-150	110	320	170	300	125	140	7	13	38	2	
ACL-HI-180	132	320	170	300	125	140	7	13	38	2	
ACL-HI-220	160	320	160	300	125	130	7	13	40	2	

### 소음 · 진동 저감용 교류리액터의 치수

전압	기종	인버터 용량 (kW)	취부 치수(mm)						규격 (K)	중량 (kg)	외형도
			A	C	H	X	T	J			
200V	ACL-L-0.4	0.4	110	90	110	40	65	6	4	2.7	1
	ACL-L-0.75	0.75	130	105	130	50	80	6	4	4.2	1
	ACL-L-1.5	1.5	160	100	160	80	75	6	4	6.6	1
	ACL-L-2.2	2.2	180	110	190	90	90	6	4	11.5	1
	ACL-L-3.7	3.7	220	110	210	125	90	6	4	14.8	1
	ACL-L-5.5	5.5	220	110	220	125	90	6	5.3	15.0	2
	ACL-L-7.5	7.5	220	130	220	120	112	7	6.7	22.0	2
	ACL-L-11	11	220	130	220	125	112	7	6.7	24.0	2
	ACL-L-15	15	270	155	250	140	125	7	6.7	37.0	2
	ACL-L-18.5	18.5	270	155	250	140	135	7	8.3	40.5	2
	ACL-L-22	22	270	170	250	140	140	7	8.3	43.0	2
	ACL-L-30	30	270	180	250	160	150	10	8.3	60.6	2
400V	ACL-L-37	37	270	180	250	160	150	10	8.3	62.0	2
	ACL-L-45	45	270	180	250	160	160	10	8.3	73.0	2
	ACL-L-55	55	270	190	250	160	180	10	10.3	76.0	2
	ACL-H-0.4	0.4	110	85	110	40	65	6	4	2.7	1
	ACL-H-0.75	0.75	130	100	130	50	80	6	4	4.2	1
	ACL-H-1.5	1.5	150	105	160	80	75	6	4	6.6	1
	ACL-H-2.2	2.2	180	105	190	90	90	6	4	11	1
	ACL-H-3.7	3.7	180	110	190	125	90	6	4	14.8	1
	ACL-H-5.5	5.5	180	110	190	125	90	6	4	15.5	1
	ACL-H-7.5	7.5	180	130	190	125	112	7	4	22	1
	ACL-H-11	11	180	130	200	125	112	7	5.3	24	2
	ACL-H-15	15	270	150	250	140	125	7	6.7	37	2
0V	ACL-H-18.5	18.5	270	165	250	140	135	7	6.7	40	2
	ACL-H-22	22	270	175	250	140	140	7	6.7	43	2
	ACL-H-30	30	270	180	250	160	150	10	8.3	60	2
	ACL-H-37	37	270	180	250	160	150	10	8.3	62	2
	ACL-H-45	45	270	190	250	160	160	10	8.3	72	2
	ACL-H-55	55	270	200	250	160	180	10	8.3	75	2
	ACL-H-75	75	270	220	250	160	190	10	8.3	93	2
	ACL-H-90	90	320	240	330	160	200	10	10.3	117	2
	ACL-H-110	110	320	280	330	160	250	10	10.3	140	2
	ACL-H-132	132	320	230	330	160	200	10	10.3	96	2

## Noise Filter for Inverter

### Dimension

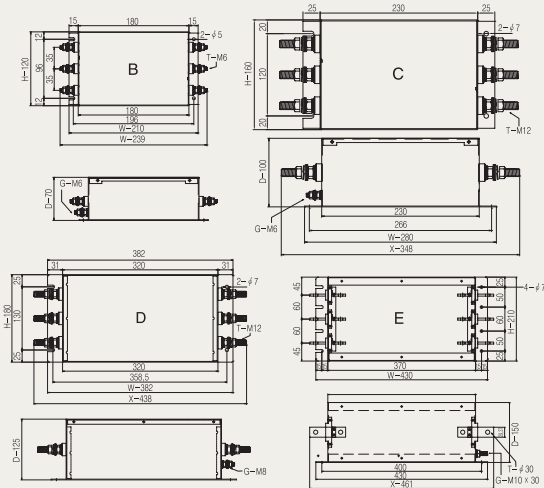

### Connecting Diagram

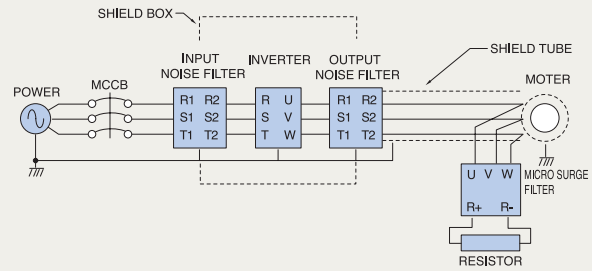

## Input Noise Filter

Model	Inverter Rated Current	Name	Specification						Type
			V	A	Size(W X H X D * X (mm))	G	T		
200V									
055LF	24A	FT-20301S-A	250V	30A	210 X 120 X 70 * 239	M6	M6	B	
075LF	32A	FT-20401S-A	250V	40A	210 X 120 X 70 * 239	M6	M6	B	
110LF	46A	FT-20501S-A	250V	50A	210 X 120 X 70 * 239	M6	M6	B	
150LF	64A	FT-20701S-A	250V	70A	280 X 160 X 100 * 348	M6	M12	C	
185LF	76A	FT-20801S-A	250V	80A	280 X 160 X 100 * 348	M6	M12	C	
220LF	95A	FT-21001S-A	250V	100A	382 X 180 X 125 * 438	M8	M12	D	
300LF	121A	FT-21301S-A	250V	130A	382 X 180 X 125 * 438	M8	M12	D	
370LF	145A	FT-21501S-A	250V	150A	430 X 210 X 150 * 461	M10	M10	E	
450LF	182A	FT-22001S-A	250V	200A	430 X 210 X 150 * 461	M10	M10	E	
550LF	220A	FT-22501S-A	250V	250A	430 X 210 X 150 * 461	M10	M10	E	
400V									
055HF	12A	FT-40201S-A	450V	20A	210 X 120 X 70 * 239	M6	M6	B	
075HF	16A	FT-40201S-A	450V	20A	210 X 120 X 70 * 239	M6	M6	B	
110HF	23A	FT-40301S-A	450V	30A	210 X 120 X 70 * 239	M6	M6	B	
150HF	32A	FT-40401S-A	450V	40A	210 X 120 X 70 * 239	M6	M6	B	
185HF	38A	FT-40401S-A	450V	40A	210 X 120 X 70 * 239	M6	M6	B	
220HF	48A	FT-40501S-A	450V	50A	210 X 120 X 70 * 239	M6	M6	B	
300HF	58A	FT-40601S-A	440V	60A	210 X 120 X 70 * 239	M6	M6	B	
370HF	75A	FT-40801S-A	440V	80A	280 X 160 X 100 * 348	M6	M12	C	
450HF	90A	FT-41001S-A	440V	100A	382 X 180 X 125 * 438	M8	M12	D	
550HF	110A	FT-41201S-A	440V	120A	382 X 180 X 125 * 438	M8	M12	D	
750HF	149A	FT-41501S-A	440V	150A	430 X 210 X 150 * 461	M10	M10	E	
900HF	176A	FT-41801S-A	440V	180A	430 X 210 X 150 * 461	M10	M10	E	
1100HF	217A	FT-42201S-A	440V	220A	430 X 210 X 150 * 461	M10	M10	E	
1320HF	260A	FT-42601S-A	440V	260A	430 X 210 X 150 * 461	M10	M10	E	

## Output Noise Filter

Model	Inverter Rated Current	Name	Specification						Type
			V	A	Size(W X H X D * X (mm))	G	T		
200V									
055LF	24A	FT-20301S-A	250V	30A	210 X 120 X 70 * 239	M6	M6	B	
075LF	32A	FT-20401S-A	250V	40A	210 X 120 X 70 * 239	M6	M6	B	
110LF	46A	FT-20501S-A	250V	50A	210 X 120 X 70 * 239	M6	M6	B	
150LF	64A	FT-20701S-A	250V	70A	280 X 160 X 100 * 348	M6	M12	C	
185LF	76A	FT-20801S-A	250V	80A	280 X 160 X 100 * 348	M6	M12	C	
220LF	95A	FT-21001S-A	250V	100A	382 X 180 X 125 * 438	M8	M12	D	
300LF	121A	FT-21301S-A	250V	130A	382 X 180 X 125 * 438	M8	M12	D	
370LF	145A	FT-21501S-A	250V	150A	430 X 210 X 150 * 461	M10	M10	E	
450LF	182A	FT-22001S-A	250V	200A	430 X 210 X 150 * 461	M10	M10	E	
550LF	220A	FT-22501S-A	250V	250A	430 X 210 X 150 * 461	M10	M10	E	
400V									
055HF	12A	FT-40201S-A	450V	20A	210 X 120 X 70 * 239	M6	M6	B	
075HF	16A	FT-40201S-A	450V	20A	210 X 120 X 70 * 239	M6	M6	B	
110HF	23A	FT-40301S-A	450V	30A	210 X 120 X 70 * 239	M6	M6	B	
150HF	32A	FT-40401S-A	450V	40A	210 X 120 X 70 * 239	M6	M6	B	
185HF	38A	FT-40401S-A	450V	40A	210 X 120 X 70 * 239	M6	M6	B	
220HF	48A	FT-40501S-A	450V	50A	210 X 120 X 70 * 239	M6	M6	B	
300HF	58A	FT-40601S-A	440V	60A	210 X 120 X 70 * 239	M6	M6	B	
370HF	75A	FT-40801S-A	440V	80A	280 X 160 X 100 * 348	M6	M12	C	
450HF	90A	FT-41001S-A	440V	100A	382 X 180 X 125 * 438	M8	M12	D	
550HF	110A	FT-41201S-A	440V	120A	382 X 180 X 125 * 438	M8	M12	D	
750HF	149A	FT-41501S-A	440V	150A	430 X 210 X 150 * 461	M10	M10	E	
900HF	176A	FT-41801S-A	440V	180A	430 X 210 X 150 * 461	M10	M10	E	
1100HF	217A	FT-42201S-A	440V	220A	430 X 210 X 150 * 461	M10	M10	E	
1320HF	260A	FT-42601S-A	440V	260A	430 X 210 X 150 * 461	M10	M10	E	

# Regenerative Braking Unit

## Specification

Item	Voltage	200V Class				400V Class							
	Model	BRD-K3				BRD-VZ3							
	Type	370L	37	45	55L	370H	37	45	55	75	90	110	132
Inverter capacity (kW) (Note1)		30	37	45	55	30	37	45	55	75	90	110	132
Max DC voltage (P-N)		DC 400V				DC 800V							
Operating voltage (P-N)		362±5V				725±5V							
Average Braking Torque		130%				130%							
Allowable Braking Rate		20~30%				20~30%							

(Note1) Inverter, up to 22kW, has a built-in BRD.

## Wiring Diagram

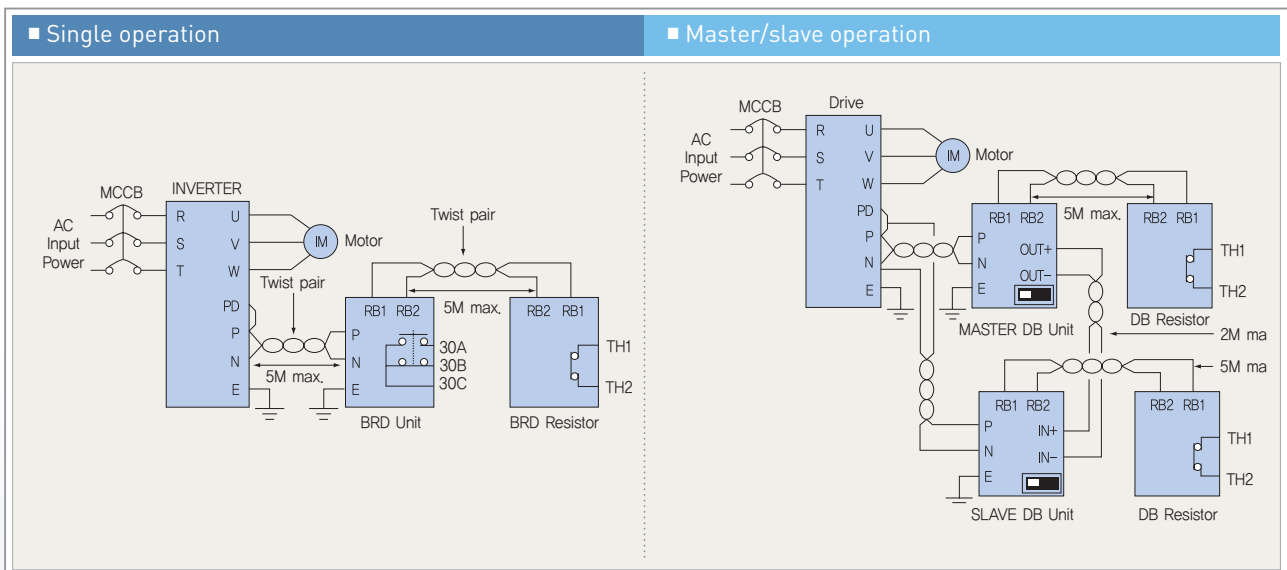

## Wiring of regenerative braking unit and braking resistor

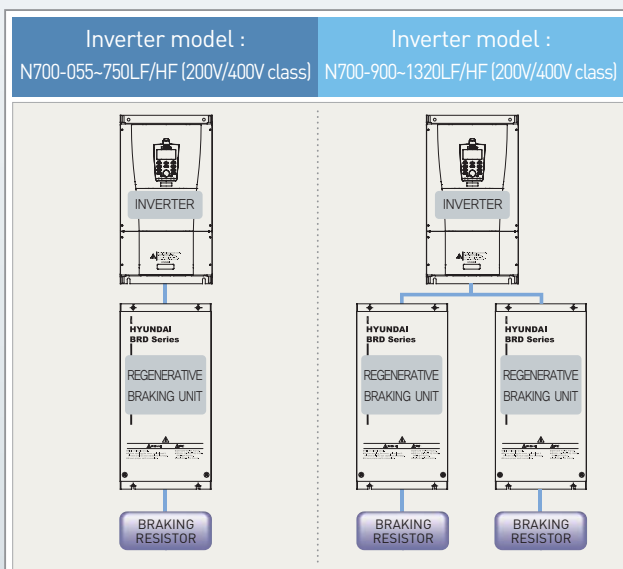

## Outline

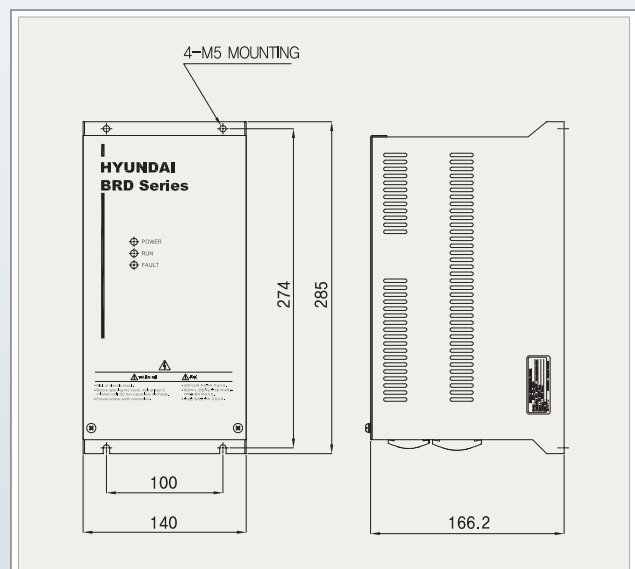

## Braking Resistor

Voltage	Inverter model	Low duty			Heavy duty			RBD UNIT
		Resistor model	Resistance(Ω)	Rated Capacity(kW)	Resistor model	Resistance(Ω)	Rated Capacity(kW)	
200V Class	N700-055LF	RB-01P0-17	17.0	1.0	RB-01P2-17	17.0	1.2	Standard Built-in
	N700-075LF							
	N700-110LF							
	N700-150LF	RB-02P5-8.7	8.7	2.5	RB-04P5-8.7	8.7	4.5	
	N700-185LF	RB-03P0-6	6.0	3.0	RB-05P6-6	6.0	5.6	
	N700-220LF	RB-04P0-6		4.0	RB-06P6-6		6.6	
	N700-300LF	RB-05P0-3.5	3.5	5.0	RB-09P0-3.5	3.5	9.0	Option
	N700-370LF	RB-06P0-3.5		6.0	RB-11P2-3.5		11.2	
	N700-450LF	RB-07P0-2.4		7.0	RB-13P5-2.4		13.5	
N700-550LF	RB-08P5-2.4	2.4	8.5	RB-16P5-2.4	2.4	16.5		
400V Class	N700-055HF	RB-01P2-70	70.0	1.2	RB-01P8-70	70.0	1.8	Standard Built-in
	N700-075HF	RB-01P2-50	50.0		RB-02P4-50	50.0	2.4	
	N700-110HF	RB-02P0-50		2.0	RB-03P3-50	20.0	3.3	
	N700-150HF	RB-02P5-30	30.0	2.5	RB-04P5-30		30.0	
	N700-185HF	RB-03P0-20	20.0	3.0	RB-05P6-20	20.0	5.6	
	N700-220HF	RB-04P0-20		4.0	RB-06P6-20		6.6	
	N700-300HF	RB-05P0-12	12.0	5.0	RB-09P0-12	12.0	9.0	Option
	N700-370HF	RB-06P0-12		6.0	RB-11P2-12		11.2	
	N700-450HF	RB-07P0-8		7.0	RB-13P5-8		13.5	
	N700-550HF	RB-08P5-8	8.0	8.5	RB-16P5-8	8.0	16.5	
	N700-750HF	RB-11P2-6	6.0	11.2	RB-22P5-6	6.0	22.5	
	N700-900HF	RB-11P2-6 (x2)	6.0 (x2)		RB-22P5-6 (x2)	6.0 (x2)		
	N700-1100HF							
	N700-1320HF							

## Outline

### A TYPE : RB-01P0~RB-02P0

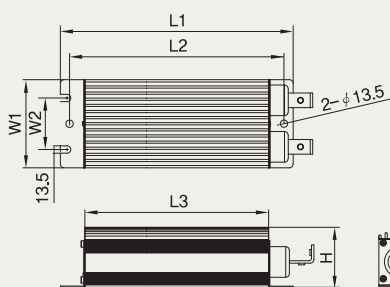

### B TYPE : RB-02P4~RB-22P5

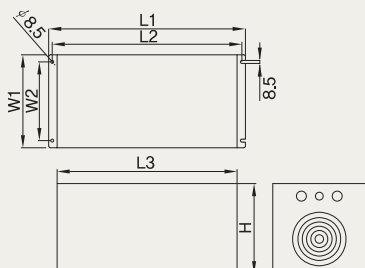

## Dimension [mm]

A TYPE	L1±1	L2±1	L3±1	W1±1	W2±1	H±1
RB-01P0	340	325	302			
RB-01P2	400	385	362	70	39	45
RB-01P8~RB-02P0	510	495	472			

B TYPE	L1±2	L2±2	L3±2	W1±2	W2±2	H±2
RB-02P4~ RB-02P5	550	530	503	180	140	126
RB-03P0				260	220	126
RB-04P0~ RB-05P0				180	140	182
RB-05P6~ RB-06P6						182
RB-08P0~ RB-09P0						252
RB-11P2~ RB-13P5				260	220	322
RB-16P5						392
RB-22P5				340	300	392

## FOR CORRECT OPERATION

- \* Before use, be sure to read through the Instruction Manual to insure proper use of the inverter.
- \* Note that the inverter requires electrical wiring; a trained specialist should carry out the wiring.
- \* The inverter in this catalog is designed for general industrial applications. For special applications in fields such as aircraft, nuclear power, transport, vehicles, clinics, and underwater equipment, please consult with us in advance.
- \* For application in a facility where human life is involved or serious losses may occur, make sure to provide safety devices to avoid a serious accident.
- \* The inverter is intended for use with a three-phase AC motor. For use with a load other than this, please consult with us.

### Application to Motors | Application to General-purpose Motors |

Operating frequency	The overspeed endurance of a general-purpose motor is 120% of the rated speed for 2 minutes (JIS C4,004). For operation at higher than 60Hz, it is required to examine the allowable torque of the motor, useful life of bearings, noise, vibration, etc. In this case, be sure to consult the motor manufacturer as the maximum allowable rpm differs depending on the motor capacity, etc.
Torque characteristics	The torque characteristics of driving a general-purpose motor with an inverter differ from those of driving it using commercial power (starting torque decreases in particular). Carefully check the load torque characteristic of a connected machine and the driving torque characteristic of the motor.
Motor loss and temperature increase	An inverter-driven general-purpose motor heats up quickly at lower speeds. Consequently, the continuous torque level (output) will decrease at lower motor speeds. Carefully check the torque characteristics vs speed range requirements.
Noise	When run by an inverter, a general-purpose motor generates noise slightly greater than with commercial power.
Vibration	When run by an inverter at variable speeds, the motor may generate vibration, especially because of (a) unbalance of the rotor including a connected machine, or (b) resonance caused by the natural vibration frequency of a mechanical system. Particularly, be careful of (b) when operating at variable speeds a machine previously fitted with a constant speed motor. Vibration can be minimized by (1) avoiding resonance points using the frequency jump function of the inverter, (2) using a tire-shaped coupling, or (3) placing a rubber shock absorber beneath the motor base.
Power transmission mechanism	Under continued, low-speed operation, oil lubrication can deteriorate in a power transmission mechanism with an oil type gear box(gear motor) or reducer. Check with the motor manufacturer for the permissible range of continuous speed. To operate at more than 60 Hz, confirm the machine's ability to withstand the centrifugal force generated.

### Application to Motors | Application to Special Motors |

Gear motor	The allowable rotation range of continuous drive varies depending on the lubrication method or motor manufacturer.(Particularly in case of oil lubrication, pay attention to the low frequency range.)
Brake-equipped motor	For use of a brake-equipped motor, be sure to connect the braking power supply from the primary side of the inverter.
Pole-change motor	There are different kinds of pole-change motors (constant output characteristic type, constant torque characteristic type, etc.), with different rated current values. In motor selection, check the maximum allowable current for each motor of a different pole count. At the time of pole change, be sure to stop the motor. Also see: Application to the 400 V class motor.
Submersible motor	The rated current of a submersible motor is significantly larger than that of the general-purpose motor. In inverter selection, be sure to check the rated current of the motor.
Explosion-proof motor	Inverter drive is not suitable for a safety-enhanced explosion-proof type motor. The inverter should be used in combination with a pressure-proof and explosion-proof type of motor. ※ Explosion-proof verification is not available for N700 series.
Synchronous (MS) motor /High-speed(HFM) motor	In most cases, the synchronous (MS) motor and the high-speed (HFM) motor are designed and manufactured to meet the specifications suitable for a connected machine. As to proper inverter selection, consult the manufacturer.
Single-phase motor	A single-phase motor is not suitable for variable-speed operation by an inverter drive. Therefore, use a three-phase motor.

### Application to Motors | Application to the 400 V-class Motor |

A system applying a voltage-type PWM inverter with IGBT may have surge voltage at the motor terminals resulting from the cable constants including the cable length and the cable laying method. Depending on the surge current magnification, the motor coil insulation may be degraded. In particular, when a 400 V class motor is used, a longer cable is used, and critical loss can occur, take the following countermeasures:(1) install the LCR filter between the inverter and the motor,(2) install the AC reactor between the inverter and the motor, or (3) enhance the insulation of the motor coil.

### Notes on Use | Drive |

Run/ Stop	Run or stop of the inverter must be done with the keys on the operator panel or through the control circuit terminal. Do not operate by installing an electromagnetic contactor (Mg) in the main circuit.
Emergency motor stop	When the protective function is operating or the power supply stops, the motor enters the free run stop state. When an emergency stop is required or when the motor should be kept stopped, use of a mechanical brake should be considered.
High-frequency run	A max. 400Hz can be selected on the N300 series. However, a two-pole motor can attain up to approx. 24,000 rpm, which is extremely dangerous. Therefore, carefully make selection and settings by checking the mechanical strength of the motor and connected machines. Consult the motor manufacturer when it is necessary to drive a standard(general-purpose) motor above 60Hz. A full line of high-speed motors is available from Hyundai.

■ Notes on Use | Installation Location and Operating Environment |

Avoid installation in areas of high temperature, excessive humidity, or where moisture can easily collect, as well as areas that are dusty, subject to corrosive gases, mist of liquid for grinding, or salt. Install the inverter away from direct sunlight in a well-ventilated room that is free of vibration. The inverter can be operated in the ambient temperature range from -10℃ to 50℃ (Carrier frequency and output current must be reduced in the range of 40℃ to 50℃)

■ Notes on Use | Main Power Supply |

Installation of an AC reactor on the input side	<p>In the following examples involving a general-purpose inverter, a large peak current flows on the main power supply side, and is able to destroy the converter module. Where such situations are foreseen or the connected equipment must be highly reliable, install an AC reactor between the power supply and the inverter. Also, where influence of indirect lightning strike is possible, install a lightning conductor.</p> <p>A) The unbalance factor of the power supply is 3% or higher. <b>(Note)</b>                  B) The power supply capacity is at least 10 times greater than the inverter capacity (the power supply capacity is 500 kVA or more).                  C) Abrupt power supply changes are expected.</p> <p>Examples)① Several inverters are interconnected with a short bus.                  ② A thyristor converter and an inverter are interconnected with a short bus.                  ③ An installed phase advance capacitor opens and closes. In cases (A), (B) and (C), it is recommended to install an AC reactor on the main power supply side.</p> <p><b>(Note):</b> Example calculation with VRS=205 V, VST=201 V, VTR=200 V                  VRS: R-S line voltage, VST: S-T line voltage, VTR: T-R line voltage</p> $\text{Unbalance factor of voltage} = \frac{\text{Max. line voltage}(\text{min.}) - \text{Max. line voltage}}{\text{Mean line voltage}} \times 100 = \frac{\text{VRS} - (\text{VRS} + \text{VST} + \text{VTR})/3}{\text{VRS} + \text{VST} + \text{VTR}/3} \times 100 = \frac{205 - 202}{202} \times 100 = 1.5(\%)$
Using a private power generator	<p>An inverter run by a private power generator may overheat the generator or suffer from a deformed output voltage wave form of the generator. Generally, the generator capacity should be five times that of the inverter (kVA) in a PWM control system, or six times greater in a PAM control system.</p>

■ Notes on Peripheral Equipment Selection

Wiring connections	<p>(1) Be sure to connect main power wires with R(L1), S(L2), and T(L3) (input) terminals and motor wires to U(T1), V(T2), and W(T3) terminals (output). (Incorrect connection will cause an immediate failure.)                  (2) Be sure to provide a grounding connection with the ground terminal (⏚)</p>				
Wiring between inverter and motor	<table border="1"> <tr> <td style="background-color: #e0e0e0;">Electromagnetic contactor</td> <td>When an electromagnetic contactor is installed between the inverter and the motor, do not perform on-off switching during running operation.</td> </tr> <tr> <td style="background-color: #e0e0e0;">Thermal relay</td> <td>When used with standard applicable output motors (standard three-phase squirrel cage four pole motors), the N300 series does not need a thermal relay for motor protection due to the internal electronic protective circuit. A thermal relay, however, should be used: during continuous running outside a range of 30 Hz to 60 Hz for motors exceeding the range of electronic thermal adjustment (rated current). When several motors are driven by the same inverter, install a thermal relay for each motor. The RC value of the thermal relay should be more than 1.1 times the rated current of the motor. Where the wiring length is 10m or more, the thermal relay tends to turn off readily. In this case, provide an AC reactor on the output side or use a current sensor.</td> </tr> </table>	Electromagnetic contactor	When an electromagnetic contactor is installed between the inverter and the motor, do not perform on-off switching during running operation.	Thermal relay	When used with standard applicable output motors (standard three-phase squirrel cage four pole motors), the N300 series does not need a thermal relay for motor protection due to the internal electronic protective circuit. A thermal relay, however, should be used: during continuous running outside a range of 30 Hz to 60 Hz for motors exceeding the range of electronic thermal adjustment (rated current). When several motors are driven by the same inverter, install a thermal relay for each motor. The RC value of the thermal relay should be more than 1.1 times the rated current of the motor. Where the wiring length is 10m or more, the thermal relay tends to turn off readily. In this case, provide an AC reactor on the output side or use a current sensor.
Electromagnetic contactor	When an electromagnetic contactor is installed between the inverter and the motor, do not perform on-off switching during running operation.				
Thermal relay	When used with standard applicable output motors (standard three-phase squirrel cage four pole motors), the N300 series does not need a thermal relay for motor protection due to the internal electronic protective circuit. A thermal relay, however, should be used: during continuous running outside a range of 30 Hz to 60 Hz for motors exceeding the range of electronic thermal adjustment (rated current). When several motors are driven by the same inverter, install a thermal relay for each motor. The RC value of the thermal relay should be more than 1.1 times the rated current of the motor. Where the wiring length is 10m or more, the thermal relay tends to turn off readily. In this case, provide an AC reactor on the output side or use a current sensor.				
Installing a circuit breaker	Install a circuit breaker on the main power input side to protect inverter wiring and ensure personal safety. Choose an inverter-compatible circuit breaker. The conventional type may malfunction due to harmonics from the inverter. For more information, consult the circuit breaker manufacturer.				
Wiring distance	The wiring distance between the inverter and the remote operator panel should be 20 meters or less. When this distance is exceeded, use CVD-E (current-voltage converter) or RCD-E (remote control device). Shielded cable should be used on the wiring. Beware of voltage drops on main circuit wires. (A large voltage drop reduces torque.)				
Earth leakage relay	If the earth leakage relay (or earth leakage breaker) is used, it should have a sensitivity level of 15mA or more (per inverter).				
Phase advance capacitor	Do not use a capacitor for power factor improvement between the inverter and the motor because the high-frequency components of the inverter output may overheat or damage the capacitor				

■ High-frequency Noise and Leakage Current

- (1) High-frequency components are included in the input/output of the inverter main circuit, and they may cause interference in a transmitter, radio, or sensor if used near the inverter. The interference can be minimized by attaching noise filters(option) in the inverter circuitry.
- (2) The switching action of an inverter causes an increase in leakage current. Be sure to ground the inverter and the motor.

■ Lifetime of Primary Parts

Because a DC bus capacitor deteriorates as it undergoes internal chemical reaction, it should normally be replaced every five years. Be aware, however, that its life expectancy is considerably shorter when the inverter is subjected to such adverse factors as high temperatures or heavy loads exceeding the rated current of the inverter. The approximate lifetime of the capacitor is as shown in the figure at the right when it is used 24 hours daily (according to the "Instructions for Periodic Inspection of General-Purpose Inverter (JEMA)"). Also, such moving parts as a cooling fan should be replaced. Maintenance inspection and parts replacement must be performed by only specified trained personnel.

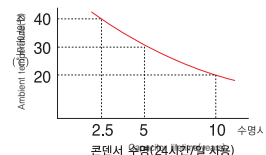

[www.hyundai-elec.com](http://www.hyundai-elec.com)



<b>Head Office</b>	1 Jeonha-dong, Dong-gu, Ulsan, Korea Tel. 82-52-202-8101~8 Fax 82-52-202-8100
<b>Seoul</b> <b>(Sales &amp; Marketing)</b>	140-2, Gye-dong, Jongno-gu, Seoul, Korea Tel. 82-2-746-7621, 8568, 7541 Fax 82-2-746-7679
<b>Orlando</b>	3452 Lake Lynda Drive, Suite 170, Orlando, Florida 32817, U.S.A. Tel. 1-407-249-7350 Fax 1-407-275-4940
<b>New Jersey</b>	300 Sylvan Avenue, Englewood Cliffs, NJ, 07632, U.S.A. Tel. 1-201-816-0286 Fax 1-201-816-4083
<b>London</b>	2nd Floor, The Triangle, 5-17 Hammersmith Grove, London, W6 0LG, UK Tel. 44-20-8741-0501 Fax 44-20-8741-5620
<b>Tokyo</b>	8th Fl., Yurakucho Denki Bldg.1-7-1, Yuraku-cho, Chiyoda-gu, Tokyo, 100-0006, Japan Tel. 81-3-3212-2076, 3215-7159 Fax 81-3-3211-2093
<b>Osaka</b>	I-Room 5th Fl. Nagahori-Plaza Bldg. 2-4-8, Minami Senba, Chuo-Ku, Osaka, Japan, 542-0081 Tel. 81-6-6261-5766, 5767 Fax 81-6-6261-5818
<b>Dubai</b>	Unit 205, Level 2, Burj Dubai Square Building No.4, Sheikh Zayed Road, P.O.Box 252458 Tel. 971-4-425-7995 Fax 971-4-425-7996
<b>Sofia</b>	1271, Sofia 41, Rojen Blvd., Bulgaria Tel. 359-2-803-3200, 3220 Fax 359-2-803-3203
<b>Yangzhong</b>	No.9 Xiandai Road, Xinba Scientific and Technologic Zone, Yangzhong, Jiangsu, P.R.C. Zip: 212212, China Tel. 86-511-8842-0666, 0212 Fax 86-511-8842-0668, 0231