

SIEMENS

SED2 Conventional Bypass Option

Operating Instructions



SIEMENS

**SED2 VFD Conventional
Bypass Option
Operating Instructions**

NOTICE

The information contained within this document is subject to change without notice and should not be construed as a commitment by Siemens Building Technologies, Inc. Siemens Building Technologies, Inc. assumes no responsibility for any errors that may appear in this document.

All software described in this document is furnished under a license and may be used or copied only in accordance with the terms of such license.

WARNING

The Siemens Building Technologies SED2 Variable Frequency Drives are shipped without EMC line filters. (The EMC filter is most commonly used in Europe.) Where local codes or customer/installation requirements dictate, separately orderable Class A line filters are available. More stringent Class B line filters are also available for most models. Installation of these filters satisfies the requirements for the EU's EMC directive.

SERVICE STATEMENT

Control devices are combined to make a system. Each control device is mechanical in nature and all mechanical components must be regularly serviced to optimize their operation. All Siemens Building Technologies, Inc. branch offices and authorized distributors offer Technical Support Programs that will ensure your continuous, trouble-free system performance.

For further information, contact your nearest Siemens Building Technologies, Inc. representative.

CREDITS

Product or company names mentioned herein may be the trademarks of their respective owners.

Copyright © 2003 by Siemens Building Technologies, Inc.

TO THE READER

Your feedback is important to us. If you have comments about this manual, please submit them to technical.editor@siemens.com.

Printed in U.S.A.

Table of Contents

How to Use this Manual	1
Manual Organization.....	1
Manual Notations.....	1
Where To Send Comments.....	1
Reference Documents.....	2
Safety Instructions	3
Conventional Bypass Option Overview	4
General Description.....	4
Operation Overview	5
Installation Instructions	7
Environmental Conditions.....	7
Mechanical Installation.....	7
Inspection.....	7
Dimensions and Weights.....	7
Mounting.....	8
Electrical Installation.....	9
Control Connections.....	11
Motor Cable Length.....	12
Access to Connection Terminals.....	13
Power and Motor Terminal Layout	
.....	Err
or! Bookmark not defined.	
Start Up Procedures	19
Preparation.....	19
Quick Commissioning Procedure.....	22
Required SED2 Parameter Settings.....	29
Technical Specifications	30
Wiring Diagrams	32
Control Terminals.....	33
Troubleshooting	34
Fuses.....	35



How to Use this Manual

Manual Organization

This manual contains the following sections:

- *How to Use this Manual* describes the organization of this manual and the symbols used throughout this manual.
- *Safety Instructions* provides general guidelines for your safety and to prevent equipment damage.
- *Conventional Bypass Option Overview* describes the Conventional Bypass Option.
- *Operation Overview*
- *Installation Instructions* provides mounting information and details on electrical connections.
- *Startup Procedures* provides step-by-step procedures to start up the Conventional Bypass Option.
- *Technical Specifications* lists Conventional Bypass Option specification data.
- *Wiring Diagrams* provides pertinent electrical connection information.
- *Troubleshooting* provides guidelines for troubleshooting the Conventional Bypass Option.

Manual Notations

Notation	Symbol	Meaning
WARNING:		Indicates that personal injury/loss of life may occur if you do not perform a procedure as specified.
CAUTION:		Indicates that equipment damage, or loss of data may occur if you do not perform a procedure as specified.
NOTES:	(No symbol)	Provides other important information or helpful hints.

Where To Send Comments

Your feedback is important to us. If you have comments about this manual, please submit them to technical.editor@siemens.com.

Reference Documents

The following SED2 VFD documentation is available from your local Siemens Building Technologies representative:

- *SED2 VFD Startup, Operation & Maintenance Manual* (125-3201), operating instructions and procedures for the SED2.
- *SED2 VFD Parameter Reference Guide* (125-3214).
- *SED2 Variable Frequency Drives Submittal Sheet* (154-042)
- *SED2 VFD with Bypass Submittal Sheet* (154-044)
-

Safety Instructions

The following general guidelines are provided for your safety, to prevent damage, and to extend the service life of the SED2 product and any connected equipment. *Read this information carefully.* Specific Warnings, Cautions, and Notes are provided in the relevant sections of this manual.

**WARNINGS:**

- The SED2 uses hazardous voltages and controls potentially dangerous rotating mechanical parts. Non-compliance with warnings or failure to follow the instructions contained in this manual can result in loss of life, severe personal injury, or serious damage to property/equipment.
- Only authorized personnel should work on this equipment, and only after becoming familiar with all local regulations and ordinances; safety notices; and installation, operation, and maintenance procedures in this manual. Successful and safe operation of this equipment depends upon its proper handling, installation, operation, and maintenance.
- Before carrying out any installation and commissioning procedures, you must read all safety instructions and warnings, including all warning labels attached to the equipment. Make sure that the warning labels are kept in a legible condition and ensure missing or damaged labels are replaced.
- Observe the regulations of Safety Code VBG 4.0 (in particular, “Permissible Deviations when Working with Live Parts”) whenever measuring or testing is performed on live equipment. Also, use suitable Conventional tools.
- Use this equipment for only the purpose specified by the manufacturer. Unauthorized modifications and the use of spare parts and accessories that are not sold or recommended by the manufacturer of the equipment can cause fires, electric shocks, and injuries.
- Prevent the general public from accessing or approaching this equipment.

NOTE: Keep these Operating Instructions near the equipment and available to all users.

Conventional Bypass Option Overview

General Description

During normal operation in a typical application, the input and output contactors close and the SED2 operates the motor (Figure 1). The bypass contactor provides the ability to operate the motor on utility power and eliminate the VFD from the motor control circuit.

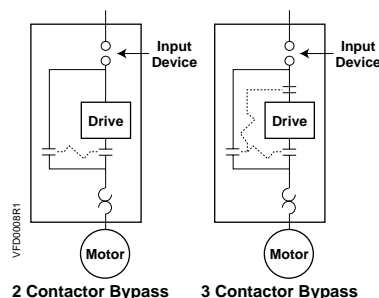

Figure 1. Functional Diagram of Typical Bypass Option.

The SED2 Conventional Bypass Option consists of a SED2, and a bypass enclosure with Conventional controls (Figure 2). The Conventional controls include:

- Control terminals
- Operators
 - "Drive-Off-Bypass" switch
 - "Bypass On" light
 - "Drive Test On-Off" switch (optional)
- Step-down control transformer
- Contactors:
 - Bypass
 - Output
 - Input (optional)
- Overload (current) relay
- Line Reactor (optional)
- Load reactor (optional)
- Disconnect switch (or optional circuit breaker)
- Fuses (optional)

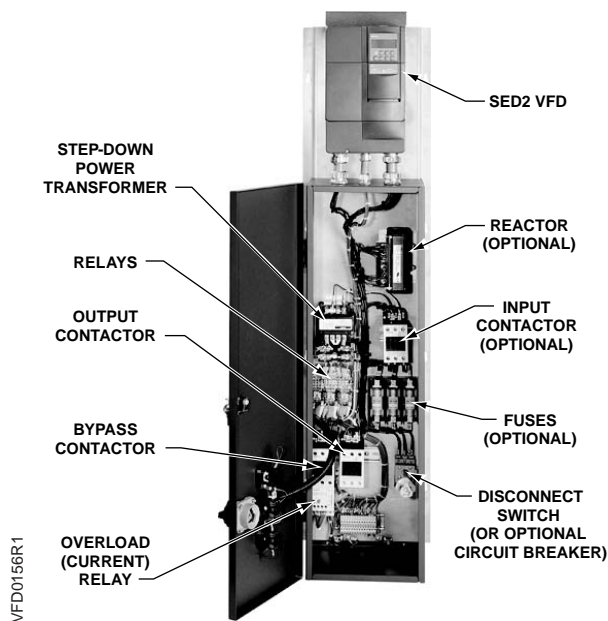

Figure 2. Typical SED2 Conventional Bypass Option Components.

Operation Overview

- **Drive Mode**
 - Drive output contactor closes (and drive input contactor if supplied). The motor is controlled by the SED2 output.
 - Change the position of the "Drive-Off-Bypass" switch to OFF or the Bypass stops the SED2 by opening digital input 4, stop 3.
- **Local Bypass Operation**
 - Requires a jumper between bypass control terminals 7 and 8. Jumper is supplied from the factory.
 - The system goes to Bypass by closing the bypass contactor. The bypass indicating light is illuminated whenever the Drive-Off-Bypass switch is placed in the Bypass mode.
 - The motor is connected to utility/line power.
- **Remote Bypass Operation**
 - Requires a jumper between bypass control terminals 5 and 6.
 - Requires that the Drive-Off-Bypass switch is in the Bypass position.
 - The system goes to Bypass by closing the bypass contactor and the bypass indicating light is illuminated whenever bypass control terminals 1 and 2 are closed (Customer Remote Start Input).
 - The motor is connected to utility/line power.
- **Automatic Bypass Operation**
 - Requires a jumper between bypass control terminals 9 and 10.
 - Requires that the Drive-Off-Bypass switch be in the Drive position.
 - The system goes to Bypass by closing the bypass contactor and the bypass indicating light is illuminated whenever the drive registers a fault condition and output relay No. 1 changes state.
 - The motor is connected to utility/line power.
 - If Remote Bypass operation is also selected, the motor will not run on bypass until the Remote Start contact closes.

Operation Overview, continued

Safety Input

- Requires a jumper between bypass control terminals 3 and 4. Jumper is supplied from the factory.
- Contact must be closed for the motor to be run in either the Drive or Bypass modes.



WARNING:

This contact disconnects the 120 Vac control power circuit.

- **Essential Service Mode**

- Closing between terminals 11 and 14 forces the bypass contactor to close regardless of the selected operation.
- All calls to open the bypass contactor are ignored except the opening of this contact or the removal of main power.



WARNING:

All calls to open the bypass include ignoring of the tripping of the mechanical overload and opening of the safety input. This procedure should be performed with extreme care.

Installation Instructions

Environmental Conditions

Install the Conventional Bypass Option in a heated, indoor controlled environment that is free of moisture and conductive contaminants such as condensation and dust. The air entering the unit for ventilation/cooling must be clean and free from corrosive gases.

The ambient temperature must be between 14°F and 104°F (-10°C to 40°C) and the relative humidity must be 0% to 95% non-condensing.

Mechanical Installation

Inspection

1. As you unpack the Conventional Bypass Option, check for shipping damage. In the event of damage, contact the transport company.
2. Locate the Conventional Bypass Option nameplate and confirm that the unit is configured to the installation requirements.
3. Verify that the delivery is complete. If not, contact the supplier.

Dimensions and Weights

Figure 5 shows overall and mounting dimensions for the Conventional Bypass Option.

Approximate weights are as follows.

Bypass Frame Size	Δ Weight lb (kg)
A	55 (25)
B	65 (29)
C	100 (45)
D	170 (77)
E	200 (91)
F	500 (227)

NOTE: Actual weight is affected by actual horsepower/ voltage and selected power options.

Mounting

1. To ensure safe installation, verify that the surface of the mounting location is level.
2. Mount the Conventional Bypass Option vertically with the SED2 operator panel, Conventional Bypass option switches, and disconnect accessible.

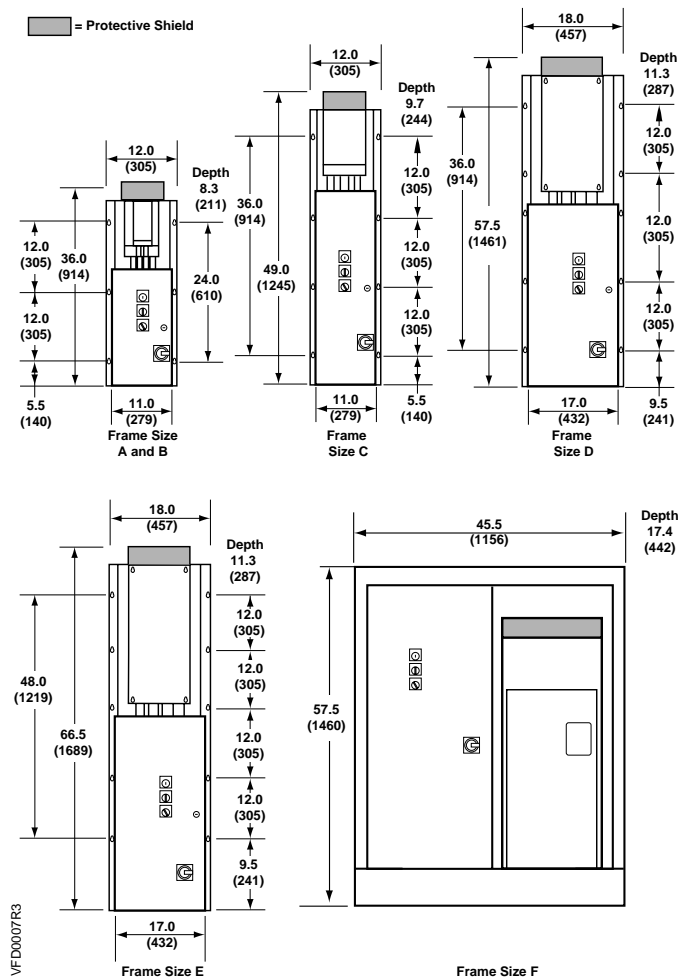

NOTE: It is recommended to leave 6 inches (152 mm) around the top and sides of the unit.

Figure 3. Conventional Bypass Option Dimensions in Inches (Millimeters).

Electrical Installation

See Figure 6 for all Conventional Bypass Option wiring.

1. Route shielded twisted pair (recommended wire type) cable, 24 gauge minimum *control wiring* in conduit through knockout and into housing (Figures 7 through 9). Connect control wiring per job-specific drawings.

NOTES:

- Terminate shield at control device.
- Control wiring is 12 to 26 AWG and tightening torque is 4.4 lb-in.



WARNING:

If applicable, route *communications wiring* in separate conduit. If wiring through bypass enclosure, locate as far from other wiring as possible.

2. Route motor wiring in conduit through knockout and into housing (Figures 7 through 8). Connect motor wiring to motor overload and ground lug. See Tables 1 through 4 for wire sizes and tightening torques.
3. Route input power wiring in conduit through knockout and into housing (Figures 7 through 8). Connect input power wiring to disconnect switch and ground lug or to circuit breaker and ground lug. See Tables 1 through 4 for wire sizes and tightening torques.

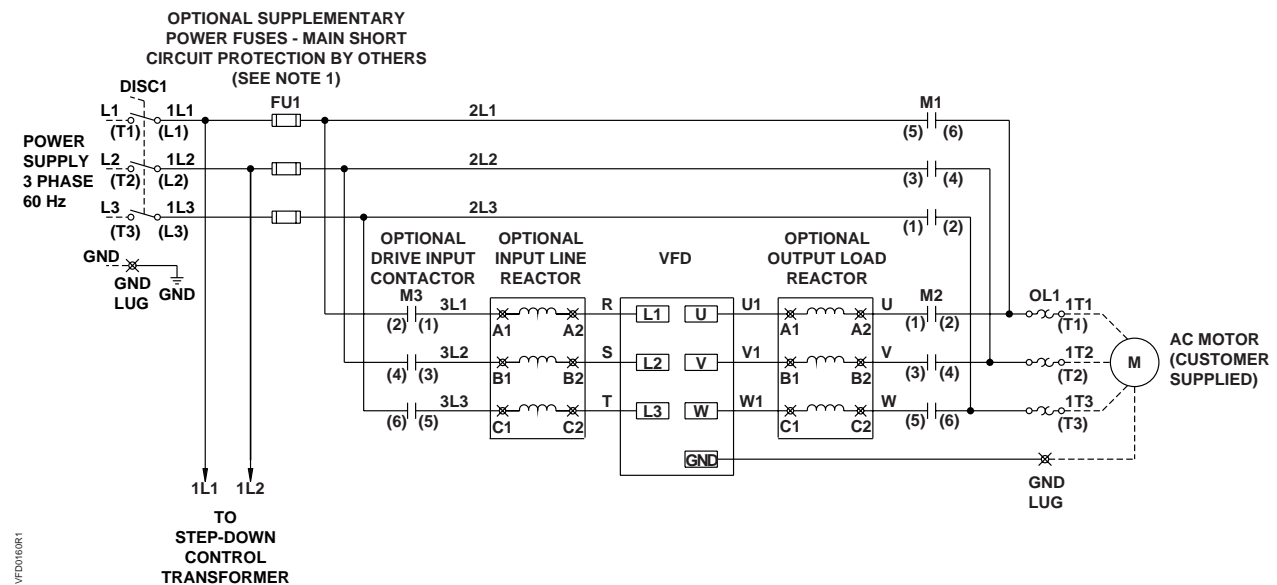

Figure 4. Conventional Bypass Option Wiring Schematic.

NOTES:

1. Branch circuit protection to be provided by installer per UL508A, if not provided with drive.
2. For Bypass operation modify these drive parameters:
P0704(0) and P0704(1) = 3, P0748 = Digital Out 1 Reverse (---→).
3. Control and communication wiring should be 300V UL minimum.
4. Communication wiring should be run with maximum separation possible from all other wiring.
5. Essential Service mode operates the motor full speed (Bypass) with no protection for the motor or system.
6. Ensure that Automatic Bypass will not damage the system before activating.
7. See Siemens' Publication *SED2 Conventional Bypass Option Operating Instruction* (125-3215) for proper fuse and wire sizes.
8. See Siemens' Publication *SED2 Startup, Operation and Maintenance Manual* (125-3201) for SED2 VFD input/output control signal wiring details.

Control Connections

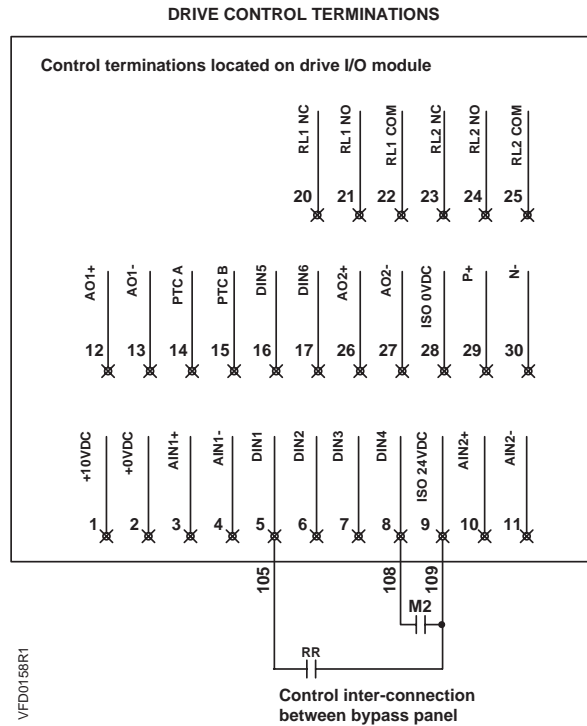

Figure 5.

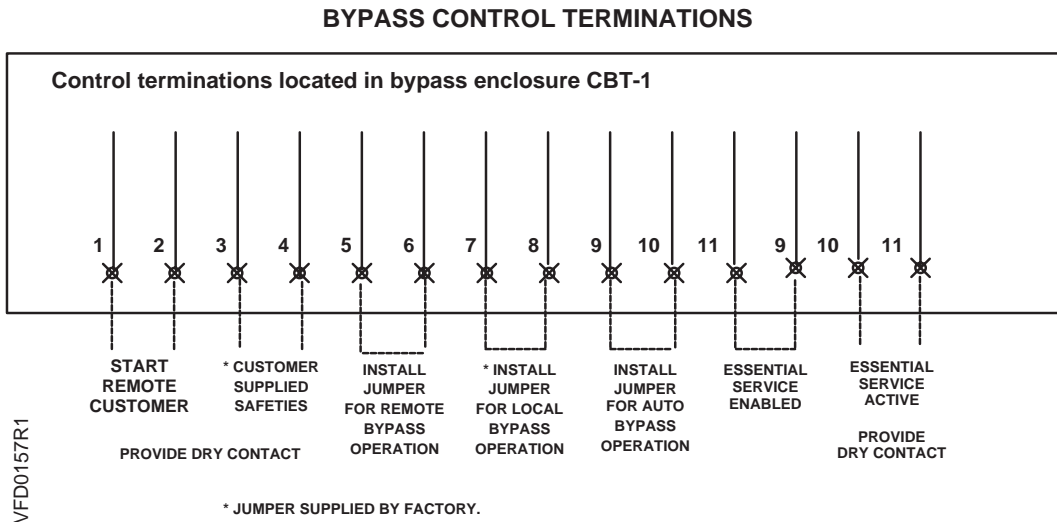

Figure 6.

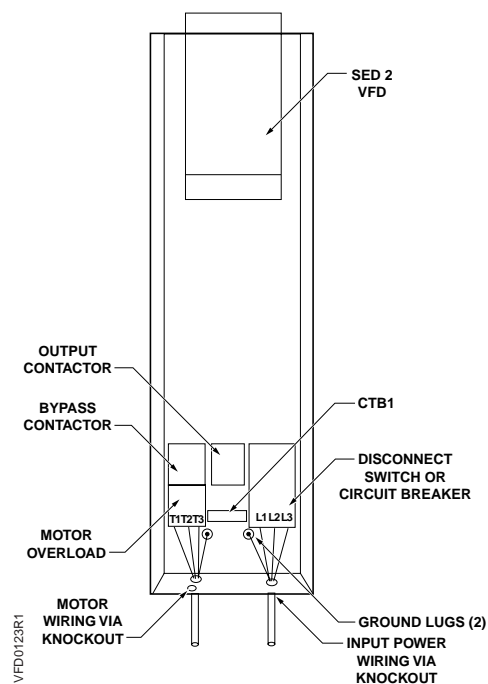

Figure 7
Routing of Power and Control Wiring for
Frame Sizes A Through E (NEMA 1).

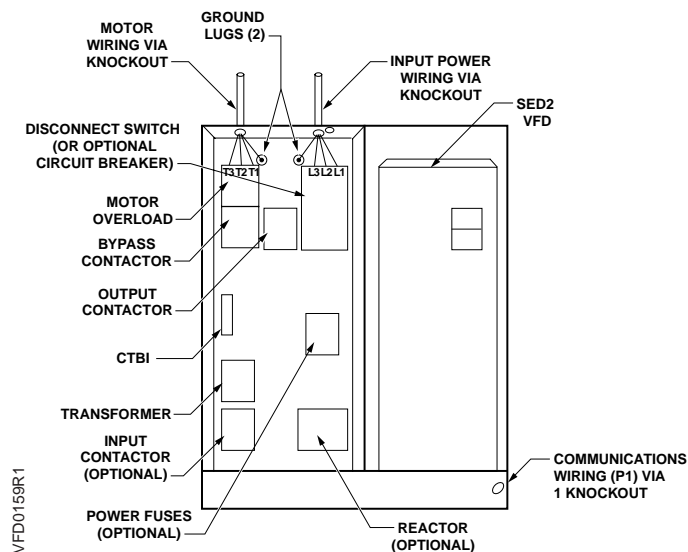

Figure 8.
Routing of Power and Control Wiring for Frame Size F.

Motor Cable Length

Motor cable length is given to ensure performance of only the drive, not the suitability of the motor when connected to a drive at this distance. See Figure 9 for installation notes.

Maximum motor cable length: 164 ft (50 m)

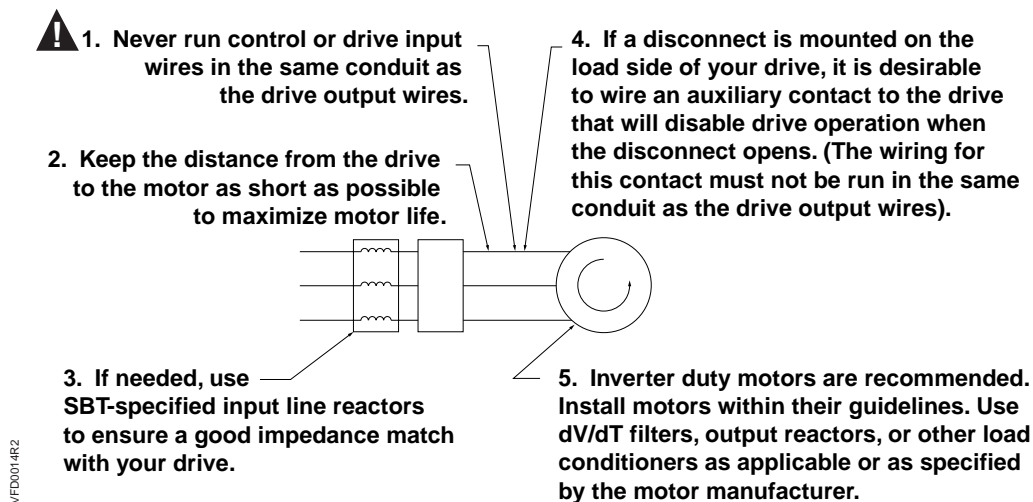
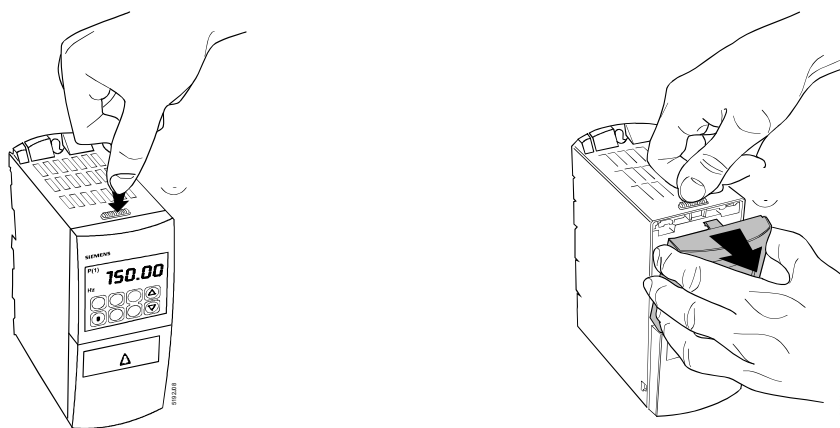

Figure 9. Motor Cable Installation Notes.

Access to Drive Connection Terminals

To access the mains power and motor terminals, remove the operator panel, cover, and I/O module.



Removing Operator Panel (BOP or AOP).

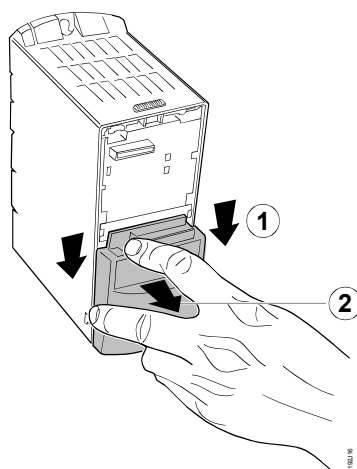

Removing Terminal Cover.

Figure 10. Access to Connection Terminals for SED2 Frame Size A.

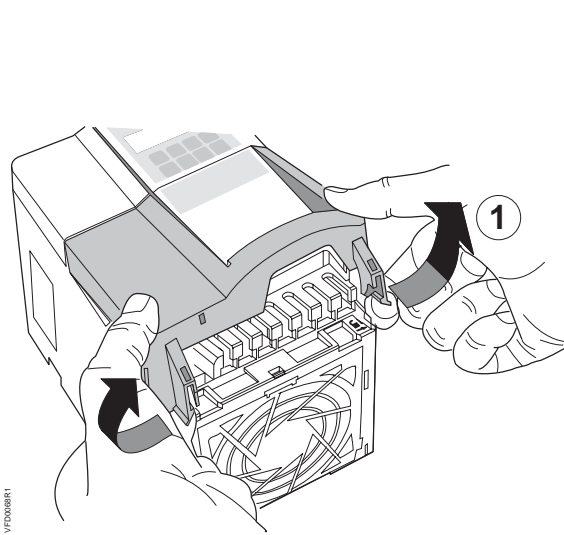

Figure 11. Access to Connection Terminals for SED2 Frame Size B and C.

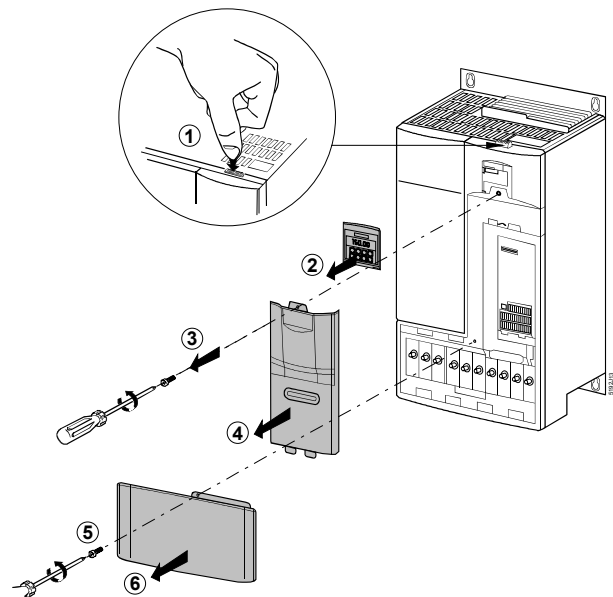

Figure 12. Access to Connection Terminals for SED2 Frame Size D and E.

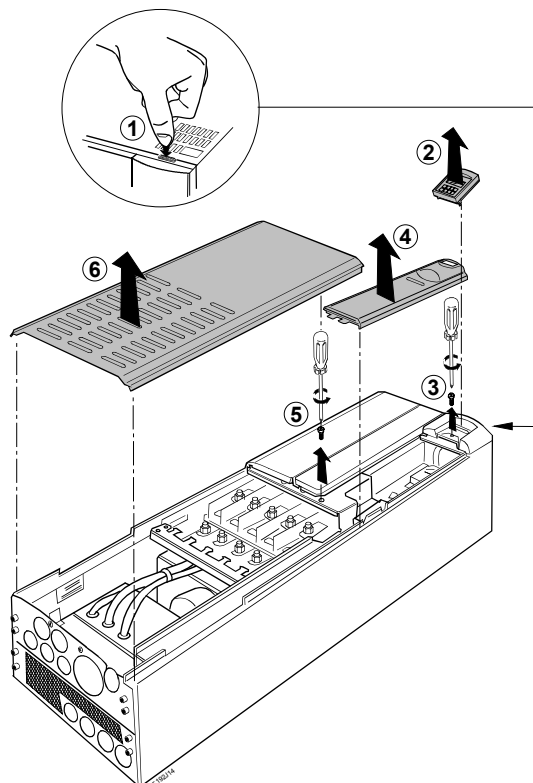

Figure 13. Access to Connection Terminals for SED2 Frame Size F.

Table 1. Wire Sizes and Tightening Torques for Conventional Bypass Option with 208V Drive.

Part Number	Bypass Frame Size	HP	kW	Amps	Circuit Breaker		Disconnect Switch		Overload			Ground Lug		
					Wire Size*	Torque, lb-in (Nm)	Wire Size*	Torque, lb-in (Nm)	Wire Size*	Torque, lb-in (Nm)	Range, Amps	Max Backup Fuse, Amps	Wire Size*	Torque, lb-in (Nm)
VBA10.5----	A	0.5	0.37	2.3	14-10 Cu	32 (3.6)	18-10	13 - (1.5 - 1.7)	18-14	7 - 10.3 (8 - 1.2)	1.8 - 2.5	10	14-2	35 (4)
VBA10.7----	A	0.7	0.55	3.0	14-10 Cu	32 (3.6)	18-10	13 - (1.5 - 1.7)	18-14	7 - 10.3 (8 - 1.2)	2.2 - 3.2	12	14-2	35 (4)
VBA11.0----	A	1.0	0.75	3.9	14-10 Cu	32 (3.6)	18-10	13 - 17 (1.5 - 1.7)	18-14	7 - 10.3 (8 - 1.2)	2.8 - 4	16	14-2	35 (4)
VBA11.5----	B	1.5	1.1	5.5	14-10 Cu	32 (3.6)	18-10	13 - (1.5 - 1.7)	18-14	7 - 10.3 (8 - 1.2)	4.5 - 6.3	25	14-2	35 (4)
VBA12.0----	B	2.0	1.5	7.4	14-10 Cu	32 (3.6)	18-10	13 - (1.5 - 1.7)	18-14	7 - 10.3 (8 - 1.2)	5.5 - 8.0	30	14-2	35 (4)
VBA13.0----	B	3.0	2.2	10.4	14-10 Cu	32 (3.6)	18-10	13 - 17 (1.5 - 1.7)	18-14	7 - 10.3 (8 - 1.2)	7 - 10	40	14-2	35 (4)
VBA15.0----	C	5.0	4.0	16.7	14-10 Cu	32 (3.6)	14-8	17 - 22 (1.9 - 2.5)	14-10	18 - 22 (2 - 25)	14 - 20	80	14-2	35 (4)
VBA17.5----	C	7.5	5.5	22.0	14-10 Cu	20 - 60 (2.2 - 6.8)	14-8	17 - 22 (1.9 - 2.5)	14-10	18 - 22 (2 - 25)	20 - 25	100	14-2	35 (4)
VBA110.----	C	10	7.5	28	10-1/0 Cu	20 - 60 (2.2 - 6.8)	14-8	17 - 22 (1.9 - 2.5)	18-3	27 - 40 (3.1 - 4.5)	22 - 32	125	14-2	35 (4)
VBA115.----	D	15	11.0	42	10-1/0 Cu	20 - 60 (2.2 - 6.8)	14-6	22 - 27 (2.5 - 3.1)	18-3	27 - 40 (3.1 - 4.5)	40 - 50	200	14-2	35 (4)
VBA120.----	D	20	15.0	54	10-1/0 Cu	20 - 60 (2.2 - 6.8)	12-1	22 - 27 (2.5 - 3.1)	10-1/0	36 - 53 (4.1 - 6)	45 - 63	250	14-2	35 (4)
VBA125.----	D	25	18.5	68	3-3/0-3 Cu	80 (9)	12-1	22 - 27 (2.5 - 3.1)	10-1/0	36 - 53 (4.1 - 6)	57 - 75	300	14-2	35 (4)
VBA130.----	E	30	22.0	80	3-3/0-3 Cu	80 (9)	12-1	22 - 27 (2.5 - 3.1)	10-1/0	36 - 53 (4.1 - 6)	70 - 90	350	14-2	35 (4)
VBA140.----	F	40	30.0	104	6 - 350 kcmil Cu	120 - 275 (14 - 31.1)	12-1	22 - 27 (2.5 - 3.1)	6-3/0	124 - 210 (14 - 23.7)	50 - 200	800	14-2/0	50 (5.6)
VBA150.----	F	50	37.0	130	6 - 350 kcmil Cu	120 - 275 (14 - 31.1)	6 - 350 kcmil	120 - 275 (13.5 - 31.1)	6-3/0	124 - 210 (14 - 23.7)	50 - 200	800	14-2/0	50 (5.6)
VBA160.----	F	60	45.0	154	6 - 350 kcmil Cu	120 - 275 (14 - 31.1)	6 - 350 kcmil	120 - 275 (13.5 - 31.1)	6-3/0	124 - 210 (14 - 23.7)	50 - 200	800	14-2/0	50 (5.6)

*Wire size in AWG unless noted otherwise. Use Copper (Cu) wire that is rated 167°F (75°C) minimum, 600 Vac.

Table 2. Wire Sizes and Tightening Torques for Conventional Bypass System with 230V - 240V Drive.

Part Number	Bypass Frame Size	HP	kW	Amps	Circuit Breaker		Disconnect Switch		Overload				Ground Lug	
					Wire Size*	Torque, lb-in (Nm)	Wire Size*	Torque, lb-in (Nm)	Wire Size*	Torque, lb-in (Nm)	Range, Amps	Max Backup Fuse, Amps	Wire Size*	Torque, lb-in (Nm)
VBA20.5----	A	0.5	0.37	2.2	14-10 Cu	32 (3.6)	18-10	13 - (1.5 - 1.7)	18-14	7 - 10.3 (8 - 1.2)	1.8 - 2.5	10	14-2	35 (4)
VBA20.7----	A	0.7	0.55	3.0	14-10 Cu	32 (3.6)	18-10	13 - (1.5 - 1.7)	18-14	7 - 10.3 (8 - 1.2)	2.2 - 3.2	12	14-2	35 (4)
VBA21.0----	A	1.0	0.75	3.9	14-10 Cu	32 (3.6)	18-10	13 - (1.5 - 1.7)	18-14	7 - 10.3 (8 - 1.2)	2.8 - 4	16	14-2	35 (4)
VBA21.5----	B	1.5	1.1	5.5	14-10 Cu	32 (3.6)	18-10	13 - (1.5 - 1.7)	18-14	7 - 10.3 (8 - 1.2)	4.5 - 6.3	25	14-2	35 (4)
VBA22.0----	B	2.0	1.5	6.8	14-10 Cu	32 (3.6)	18-10	13 - (1.5 - 1.7)	18-14	7 - 10.3 (8 - 1.2)	5.5 - 8.0	30	14-2	35 (4)
VBA23.0----	B	3.0	2.2	9.6	14-10 Cu	32 (3.6)	18-10	13 - (1.5 - 1.7)	18-14	7 - 10.3 (8 - 1.2)	7 - 10	40	14-2	35 (4)
VBA25.0----	C	5.0	4.0	15.2	14-10 Cu	32 (3.6)	14-8	17 - 22 (1.9 - 2.5)	14-10	18 - 22 (2 - 25)	14 - 20	80	14-2	35 (4)
VBA27.5----	C	7.5	5.5	22	14-10 Cu	20 - 60 (2.2 - 6.8)	14-8	17 - 22 (1.9 - 2.5)	14-10	18 - 22 (2 - 25)	20 - 25	100	14-2	35 (4)
VBA210----	C	10	7.5	28	10-1/0 Cu	20 - 60 (2.2 - 6.8)	14-8	17 - 22 (1.9 - 2.5)	18-3	27 - 40 (3.1 - 4.5)	22 - 32	125	14-2	35 (4)
VBA215----	D	15	11.0	42	10-1/0 Cu	20 - 60 (2.2 - 6.8)	14-6	22 - 27 (2.5 - 3.1)	18-3	27 - 40 (3.1 - 4.5)	40 - 50	200	14-2	35 (4)
VBA220----	D	20	15.0	54	10-1/0 Cu	20 - 60 (2.2 - 6.8)	12-1	22 - 27 (2.5 - 3.1)	10-1/0	36 - 53 (4.1 - 6)	45 - 63	250	14-2	35 (4)
VBA225----	D	25	18.5	68	3-3/0-3 Cu	80 (9)	12-1	22 - 27 (2.5 - 3.1)	10-1/0	36 - 53 (4.1 - 6)	57 - 75	300	14-2	35 (4)
VBA230----	E	30	22.0	80	3-3/0-3 Cu	80 (9)	12-1	22 - 27 (2.5 - 3.1)	10-1/0	36 - 53 (4.1 - 6)	70 - 90	350	14-2	35 (4)
VBA240----	F	40	30.0	104	6 - 350 kcmil Cu	120 - 275 (14 - 31.1)	12-1	22 - 27 (2.5 - 3.1)	6-3/0	124 - 210 (14 - 23.7)	50 - 200	800	14-2/0	50 (5.6)
VBA250----	F	50	37.0	130	6 - 350 kcmil Cu	120 - 275 (14 - 31.1)	6 - 350 kcmil	120 - 275 (13.5 - 31.1)	6-3/0	124 - 210 (14 - 23.7)	50 - 200	800	14-2/0	50 (5.6)
VBA260----	F	60	45.0	154	6 - 350 kcmil Cu	120 - 275 (14 - 31.1)	6 - 350 kcmil	120 - 275 (13.5 - 31.1)	6-3/0	124 - 210 (14 - 23.7)	50 - 200	800	14-2/0	50 (5.6)

* Wire size is AWG unless noted otherwise. Use Copper (Cu) wire that is rated 167°F (75°C) minimum 600 Vac.

Table 3. Wire Sizes and Tightening Torques for Conventional Bypass System with 380V - 480V Drive.

Part Number	Bypass Frame Size	HP	kW	Amps	Circuit Breaker		Disconnect Switch		Overload				Ground Lug	
					Wire Size*	Torque, lb-in (Nm)	Wire Size*	Torque, lb-in (Nm)	Wire Size*	Torque, lb-in (Nm)	Range, Amps	Max Backup Fuse, Amps	Wire Size*	Torque, lb-in (Nm)
VBA30.5----	A	0.5	0.37	1.1	14-10 Cu	32 (3.6)	18-10	13 - 17 (1.5 - 1.7)	18-14	7 - 10.3 (8 - 1.2)	.7 - 1.0	4	14-2	35 (4)
VBA30.7----	A	0.7	0.55	1.6	14-10 Cu	32 (3.6)	18-10	13 - 17 (1.5 - 1.7)	18-14	7 - 10.3 (8 - 1.2)	1.1 - 1.6	6	14-2	35 (4)
VBA31.0----	A	1.0	0.75	2.1	14-10 Cu	32 (3.6)	18-10	13 - 17 (1.5 - 1.7)	18-14	7 - 10.3 (8 - 1.2)	1.4 - 2.0	8	14-2	35 (4)
VBA31.5----	A	1.5	1.1	3.0	14-10 Cu	32 (3.6)	18-10	13 - 17 (1.5 - 1.7)	18-14	7 - 10.3 (8 - 1.2)	2.2 - 3.2	12	14-2	35 (4)
VBA32.0----	A	2.0	1.5	3.4	14-10 Cu	32 (3.6)	18-10	13 - 17 (1.5 - 1.7)	18-14	7 - 10.3 (8 - 1.2)	2.8 - 4	16	14-2	35 (4)
VBA33.0----	B	3.0	2.2	4.8	14-10 Cu	32 (3.6)	18-10	13 - 17 (1.5 - 1.7)	18-14	7 - 10.3 (8 - 1.2)	3.5 - 5	20	14-2	35 (4)
VBA35.0----	B	5.0	4.0	7.6	14-10 Cu	32 (3.6)	18-10	13 - 17 (1.5 - 1.7)	18-14	7 - 10.3 (.8 - 1.2)	7 - 10	40	14-2	35 (4)
VBA37.5----	C	7.5	5.5	11	14-10 Cu	32 (3.6)	18-10	13 - 17 (1.5 - 1.7)	18-14	7 - 10.3 (8 - 1.2)	9 - 12	45	14-2	35 (4)
VBA310----	C	10	7.5	14	14-10 Cu	32 (3.6)	18-10	13 to 17 (1.5 - 1.7)	14-10	18 - 22 (2 - 2.5)	11 - 16	60	14-2	35 (4)
VBA315----	C	15	11.0	21	14-10 Cu	20 - 60 (2.2 - 6.8)	14-8	17 - 22 (1.9 - 2.5)	14-10	18 - 22 (2 - 2.5)	17 - 22	80	14-2	35 (4)
VBA320----	C	20	15.0	27	10-1/0 Cu	20 - 60 (2.2 - 6.8)	14-8	17 - 22 (1.9 - 2.5)	18-3	27 - 40 (3.1 - 4.5)	22 - 32	125	14-2	35 (4)
VBA325----	D	25	18.5	34	10-1/0 Cu	20 - 60 (2.2 - 6.8)	14-6	22 - 27 (2.5 - 3.1)	18-3	27 - 40 (3.1 - 4.5)	28 - 40	150	14-2	35 (4)
VBA330----	D	30	22.0	40	10-1/0 Cu	20 - 60 (2.2 - 6.8)	14-6	22 - 27 (2.5 - 3.1)	18-3	27 - 40 (3.1 - 4.5)	28 - 40	150	14-2	35 (4)
VBA340----	D	40	30.0	52	10-1/0 Cu	20 - 60 (2.2 - 6.8)	14-6	22 - 27 (2.5 - 3.1)	18-3	27 - 40 (3.1 - 4.5)	40 - 50	200	14-2	35 (4)
VBA350----	E	50	37.0	65	10-1/0 Cu	20 - 60 (2.2 - 6.8)	12-1	22 - 27 (2.5 - 3.1)	10-1/0	36 - 53 (4.1 - 6)	57 - 75	300	14-2	35 (4)
VBA360----	E	60	45.0	77	3-3/0 Cu	80 (9)	12-1	22 - 27 (2.5 - 3.1)	10-1/0	36 - 53 (4.1 - 6)	70 - 90	350	14-2	35 (4)
VBA375----	F	75	55.0	96	3-3/0 Cu	80 (9)	12-1	22 - 27 (2.5 - 3.1)	10-1/0	36 - 53 (4.1 - 6)	80 - 100	400	14-2/0	50 (5.6)
VBA3100----	F	100	75.0	124	6 - 350 kcmil Cu	120 - 275 (14 - 31.1)	6 - 350 kcmil	120 - 275 (13.5 - 31.1)	6-3/0	124 - 210 (14 - 23.7)	50 - 200	800	14-2/0	50 (5.6)
VBA3125----	F	125	90.0	156	6 - 350 kcmil Cu	120 - 275 (14 - 31.1)	6 - 350 kcmil	120 - 275 (13.5 - 31.1)	6-3/0	124 - 210 (14 - 23.7)	50 - 200	800	14-2/0	50 (5.6)
VBA3125--HA	F	—	90.0	178	6 - 350 kcmil Cu	120 - 275 (14 - 31.1)	6 - 350 kcmil	120 - 275 (13.5 - 31.1)	6-3/0	124 - 210 (14 - 23.7)	50 - 200	800	14-2/0	50 (5.6)

* Wire size is AWG unless noted otherwise. Use Copper (Cu) wire that is rated 167°F (75°C) minimum 600 Vac.

Table 4. Wire Sizes and Tightening Torques for Conventional Bypass System with 500V - 600V Drive.

Part Number	Bypass Frame Size	HP	kW	Amps	Circuit Breaker		Disconnect Switch		Overload				Ground Lug	
					Wire Size*	Torque, lb-in (Nm)	Wire Size*	Torque, lb-in (Nm)	Wire Size*	Torque, lb-in (Nm)	Range-Amps	Max Backup Fuse, Amps	Wire Size*	Torque, lb-in (Nm)
VBA40.5----	C	0.5	0.37	.9	14-10 Cu	32 (3.6)	18-10	13 - 17 (1.5 - 1.7)	18-14	7 - 10.3 (8 - 1.2)	.7 - 1.0	4	14-2	35 (4)
VBA40.7----	C	0.7	0.55	1.3	14-10 Cu	32 (3.6)	18-10	13 - 17 (1.5 - 1.7)	18-14	7 - 10.3 (8 - 1.2)	.9 - 1.25	5	14-2	35 (4)
VBA41.0----	C	1.0	0.75	1.4	14-10 Cu	32 (3.6)	18-10	13 - 17 (1.5 - 1.7)	18-14	7 - 10.3 (8 - 1.2)	1.1 - 1.6	6	14-2	35 (4)
VBA41.5----	C	1.5	1.1	2.1	14-10 Cu	32 (3.6)	18-10	13 - 17 (1.5 - 1.7)	18-14	7 - 10.3 (8 - 1.2)	1.8 - 2.5	10	14-2	35 (4)
VBA42.0----	C	2.0	1.5	2.7	14-10 Cu	32 (3.6)	18-10	13 - 17 (1.5 - 1.7)	18-14	7 - 10.3 (8 - 1.2)	2.2 - 3.2	12	14-2	35 (4)
VBA43.0----	C	3.0	2.2	3.9	14-10 Cu	32 (3.6)	18-10	13 - 17 (1.5 - 1.7)	18-14	7 - 10.3 (8 - 1.2)	2.8 - 4	16	14-2	35 (4)
VBA45.0----	C	5.0	4.0	6.1	14-10 Cu	32 (3.6)	18-10	13 - 17 (1.5 - 1.7)	18-14	7 - 10.3 (8 - 1.2)	4.5 - 6.3	25	14-2	35 (4)
VBA47.5----	C	7.5	5.5	9	14-10 Cu	32 (3.6)	18-10	13 - 17 (1.5 - 1.7)	18-14	7 - 10.3 (8 - 1.2)	7 - 10	40	14-2	35 (4)
VBA410.----	C	10	7.5	11	14-10 Cu	32 (3.6)	18-10	13 - 17 (1.5 - 1.7)	18-14	7 - 10.3 (8 - 1.2)	9 - 2	45	14-2	35 (4)
VBA415.----	C	15	11.0	17	14-10 Cu	32 (3.6)	14-8	17 - 22 (1.9 - 2.5)	14-10	18 - 22 (2 - 2.5)	14 - 20	80	14-2	35 (4)
VBA420.----	C	20	15.0	22	10-1/0 Cu	20 - 60 (2.2 - 6.8)	14-8	17 - 22 (1.9 - 2.5)	14-10	18 - 22 (2 - 2.5)	17 - 22	80	14-2	35 (4)
VBA425.----	C	25	18.5	27	10-1/0 Cu	20 - 60 (2.2 - 6.8)	14-6	22 - 27 (2.5 - 3.1)	18-3	27 - 40 (3.1 - 4.5)	22 - 32	125	14-2	35 (4)
VBA430.----	D	30	22.0	32	10-1/0 Cu	20 - 60 (2.2 - 6.8)	14-6	22 - 27 (2.5 - 3.1)	18-3	27 - 40 (3.1 - 4.5)	28 - 40	150	14-2	35 (4)
VBA440.----	D	40	30.0	41	10-1/0 Cu	20 - 60 (2.2 - 6.8)	14-6	22 - 27 (2.5 - 3.1)	18-3	27 - 40 (3.1 - 4.5)	36 - 45	175	14-2	35 (4)
VBA450.----	E	50	37.0	52	10-1/0 Cu	20 - 60 (2.2 - 6.8)	14-6	22 - 27 (2.5 - 3.1)	18-3	27 - 40 (3.1 - 4.5)	40 - 50	200	14-2	35 (4)
VBA460.----	E	60	45.0	62	10-1/0 Cu	20 - 60 (2.2 - 6.8)	12-1	22 - 27 (2.5 - 3.1)	10-1/0	36 - 53 (4.1 - 6)	45 - 63	250	14-2	35 (4)
VBA475.----	F	75	55.0	77	3-3/0 Cu	80 (9)	12-1	22 - 27 (2.5 - 3.1)	10-1/0	36 - 53 (4.1 - 6)	70 - 90	350	14-2/0	50 (5.6)
VBA4100.----	F	100	75.0	99	3-3/0 Cu	80 (9)	12-1	22 - 27 (2.5 - 3.1)	10-1/0	36 - 53 (4.1 - 6)	80 - 100	400	14-2/0	50 (5.6)
VBA4125.----	F	125	90.0	125	6 - 350 kcmil Cu	120 - 275 (14 - 31.1)	6 - 350 kcmil	120 - 275 (14 - 31.1)	10-1/0	124 - 210 (14 - 23.7)	50 - 200	800	14-2/0	50 (5.6)

* Wire Size in AWG unless noted otherwise. Use Copper (Cu) wire that is rated 167°F (75°C) minimum, 600 Vac.

Start Up Procedures

Preparation

- | Check | Step |
|-------|---|
| () | 1. The SED2 is thoroughly tested at the factory. Verify that the drive is free of shipping and installation damage. Shipping damage is not covered by the Siemens warranty; claims must be filed directly with the shipping company as soon as possible. |
| () | 2. Review the <i>Startup, Operation, and Maintenance Manual</i> (125-3201). Review option instructions and schematics shipped with the drive. |
| () | 3. Verify that the model numbers and the voltage ratings are as specified in the purchase order by matching the nameplate data for each unit to the purchase order. |
| () | 4. Verify that the drive has been installed in accordance with the mechanical and electrical installation sections in the <i>Startup, Operation, and Maintenance Manual</i> (125-3201).. |
| |  <p>CAUTION: Failure to comply with mechanical and electrical installation requirements may void the product warranty.</p> |
| () | 5. Verify that the 50/60 Hz DIP switch has been set to the appropriate setting, as instructed in <i>Startup, Operation, and Maintenance Manual</i> (125-3201).. |
| () | 6. Inspect the security of the supply line power, ground connections, and all control circuit connections as identified in the SED2 documents. |
| | <p>IMPORTANT: Confirm that the incoming line power supply connects to the drive input terminals (L1(r), L2(s), L3(t)) and NOT to the output motor terminals (T1(u), T2(v), T3(w)).</p> <p>IMPORTANT: Double check all power wires (L1(r), L2(s), L3(t)) and motor wires (T1(u), T2(v), T3(w)) to make sure that they are securely tightened down to their respective lugs. Loose wire connections may cause problems at any time, and are not covered under warranty.</p> |
| () | 7. Review the installer's "as wired" schematic. Determine where the motor "safety circuit" is connected. Verify that the customer's emergency contacts are properly terminated in the drive's safety shutdown circuit or bypass panel. |
| | Verify that all other field-installed wires are correctly terminated (including the shields). |
| () | 8. Record the motor(s) nameplate information: |
| | Voltage: _____ Service Factor: _____ /Efficiency _____ |
| | _____ |
| | Full Load Amps (FLA): _____ RPM: _____ |
| () | 9. Verify that the input voltage matches the drive's rating. |
| () | 10. Verify that the <i>motor</i> is wired for the application voltage. |
| () | 11. IMPORTANT: Verify that the motor rated full load amps (FLA) does NOT exceed the rated output current of the drive controlling it. |
| | When multiple motors are simultaneously operated by the drive, the sum of all motor rated FLA values must be less than or equal to that of the bypass controlling them. |
| () | 12. Record any other connections to the drive by terminal number to determine if special programming is required. |
| () | 13. If applicable, verify that the building automation system logic is ready to perform adequately for start, stop, and speed command functions. |

This concludes the preparation process for SED2 startup.

Keep your Installation & Startup, Operation & Maintenance Manuals, option schematics, and any other instructions sent with the drive easily accessible to assist you through the remainder of this startup process.

- | Check | Step |
|-------|---|
| () | 1. Verify that the electrical supply power lines connect to the input device and that the motor leads connect to the output terminals of the overload relay. Ensure that all connections are <i>tight</i> ; factory connections may come loose during shipment. Set the thermal mechanical overload for the bypass panel to the motor's FLA. |
| () | 2. Record all other connections to the bypass cabinet or the VFD and confirm (if applicable) that the building management system logic is ready to perform adequately for start, stop, and speed command functions. |
| () | 3. Before applying power, make sure that the following conditions are met: <ol style="list-style-type: none"> 1. The Drive-Off-Bypass switch is OFF. 2. For units with three contactors, the Drive Test ON/OFF switch is OFF. |
| () | 4. Apply power to the drive and bypass package. Make sure that all three phases are present and that the input voltage is correct for the system being set up. Then move the Drive-Off-Bypass switch to the DRIVE position.

At this time, if the display indicates a fault, press Fn to reset it. |
| () | 5. Verify that the drive display is ON. |
| () | 6. Press P to access Parameter r0000 and to enter the SED2 programming mode. From here, you can access and change Level 1 parameters using ▲ or ▼ .

Press ▲ to advance to P0003. Press P to access parameter. Press ▲ to advance to 3. Press P to save. |
| () | 7. Repeatedly press ▲ to advance to Parameter P0010. Press P to access the parameter values level.

Press ▲ to advance to 1. Press P to confirm and save the P0010 = 1 setting. The Quick Commissioning procedure starts. See the <i>Quick Commissioning Procedure</i> section in this document for details.

On completion of the Quick Commissioning procedure, continue with Step 8. |
| () | 8. Press Fn and then P to return to the drive operating mode. |
| () | 9. To start the Drive, press Hand and then I (green start key). The drive will ramp up to "10 HZ" (or minimum speed). Verify that the direction of motor rotation is correct.

NOTE: If the direction of motor rotation is wrong, turn the Drive-Off-Bypass switch to OFF; and <i>turn Power Off!</i> Wait for five minutes.

Swap wires on the motor terminals (T1(u), T2(v)) or on the output terminals of the motor overload relay. Tighten the terminal lugs, reapply power, turn Drive-Off-Bypass switch to DRIVE, and recheck the direction of motor rotation. |
| () | 10. With correct motor rotation, manually run the drive throughout its entire operating range while observing operation. <ul style="list-style-type: none"> • If the drive trips on over-current during acceleration, adjust the acceleration time rate via Parameter P1120. • If the drive trips on over-voltage during deceleration, adjust the deceleration time rate via Parameter P1121. • If excessive vibration of the driven load is noted at specific input frequencies, use Skip Frequency Parameters P1091 through P1094 to eliminate this vibration. |

- () 11. Determine whether the remote speed reference is a 0 to 10 Vdc or a 4 to 20 mA signal. Connect signal wires and place analog input DIP Switch in the appropriate position.
- () 11. Check the signal for proper polarity. Observe if the remote speed command can achieve the minimum and maximum speeds desired. If not, scale as required.
- () 13. Set the Drive-Off-Bypass switch to **OFF**. When the drive is in the run mode, it will coast to a stop.
For units with three contactors, set the Drive Test ON/OFF switch to **ON**. Verify that the drive input contactor energizes.
- () 14. Make additional drive application parameter settings as required and record them for future reference.
- () 15. **BYPASS TEST**—Be prepared to monitor rotation of the motor in bypass operation. “Bump” the Drive-Off-Bypass switch to **BYPASS** and then quickly back to **OFF**. Check the motor rotation.
-  **CAUTION:** Do NOT allow the motor to operate in bypass mode unless the motor rotation is correct.
- () 16. If motor rotation in bypass mode is correct, proceed to Step 17.
If motor rotation in bypass mode is NOT correct, check the following and perform as described:
- Turn OFF the incoming power feed to the drive. Since the correct rotation in drive mode was previously established, do not change any output wires at motor.
 - Instead, verify that power to the input device is OFF. Swap L1 & L2 on the input side of the circuit breaker/disconnect switch. This will affect rotation in the bypass operation only. Once connections are complete and tight, reapply incoming power and repeat Step 15 to recheck the rotation direction.
- () 17. **Verify that running at full speed will NOT damage the system.**
Run the motor in bypass by turning the Drive-Off-Bypass switch to **BYPASS**.
Record all the phase voltages and currents at this time to ensure that they are balanced and within ratings.
- () 18. Turn the Drive-Off-Bypass switch to **DRIVE** and set panel to auto start/stop. Check speed references from application specific devices for appropriate operation.

This completes the startup procedure for the SED2 with Bypass Option.











Quick Commissioning Procedure

















Parameter P0010 is the Commissioning Parameter Filter. It allows you to select a group of parameters that can be used for quick commissioning, including motor data, and motor ramp-up and ramp-down settings.

It is important to use parameter P0010 to commission the SED2, P0003 to select the access level for using parameters, and P0004 to filter the parameters according to their functionality. When Commissioning Parameter Filter P0010 = 1, it initiates the quick commissioning procedure.









It is recommended that you use the quick commissioning procedure. However, experienced users may commission the equipment without the P0004 filter functions.

At the end of the quick commissioning procedure, set parameter P3900 = 3. This setting performs the necessary motor calculations and sets all remaining parameters (those not included in P0010 = 1) to the factory default values. If 3900 is set to a value greater than 0, P0010 is automatically reset to 0. (If P0010 = 1, the SED2 cannot start.) The process of performing motor calculations and setting all parameters to factory default values is only possible via quick commissioning.









Parameter	Description	Action	Setting/Default
P0003	<p>User Access Level Allows you to access more parameters.</p> <p>1 = Standard 2 = Extended 3 = Expert</p>	<ol style="list-style-type: none"> 1. Press  to access parameter r0000 and to enter the SED2 parameter mode. 2. Press  to advance to parameter P0003. 3. Press  to access the parameter values level. 4. Press  to advance to 3 (expert level). 5. Press  to confirm and save the P0003=3 setting. 	<p>Setting = 3 Default = 1</p>
<p>NOTE: Before starting quick commissioning, set P0003 = 3 to ensure all necessary parameters are available during quick commissioning.</p>			
P0010	<p>Quick Commissioning 0 = Ready to Run 1 = Quick Commissioning 30 = Factory Setting</p>	<ol style="list-style-type: none"> 1. Press  to access parameter r0000 and to enter the SED2 parameter mode. 2. Repeatedly press  to advance to parameter P0010. 3. Press  to access the parameter values level. 4. Press  to advance to 1. 5. Press  to confirm and save the P0010 =1 setting. 	<p>Setting = 1 Default = 0</p>
<p>NOTES:</p> <ol style="list-style-type: none"> 1. P0010 <i>must always</i> be set back to 0 before operating the motor. 2. If P3900 is greater than 0 on completion of commissioning, P0010 is automatically set back to 0. 			

Parameter	Description	Action	Setting/Default
P0100	<p>Operation for Europe/N. America</p> <p>0 = 50 Hz, kW (Europe) factory default</p> <p>1 = 60 Hz, hp (North America)</p> <p>The setting of Motor Frequency and Unit of Measurement DIP switch 2 overrides P0100 settings 0 and 1.</p>	<ol style="list-style-type: none"> 1. Press  to advance to parameter P0100 2. Press  to access the parameter values level. 3. Press  to advance to 1. 4. Press  to confirm and save the P0100 = 1 setting. 	<p>Setting = 1</p> <p>Default = 0 or 1 (Default is determined by the setting of the motor frequency and unit of measurement DIP switches.)</p>
<p>NOTES:</p> <ol style="list-style-type: none"> 1. Stop the SED2 (that is, disable all pulses) before changing this parameter. 2. Changing P0100 resets all rated motor parameters as well as other parameters that depend on the rated motor parameters (such as P0340, Calculation of motor Parameters). 			
P0304*	<p>Rated Motor Voltage</p> <p>10V to 2000V.</p> <p>Rated motor voltage (V) from motor nameplate.</p>	<ol style="list-style-type: none"> 1. Press  to advance to parameter P0304. 2. Press  to access the parameter values level. 3. Press  to advance to nominal voltage. 4. Press  to confirm and save the setting. 	<p>Setting = Motor nameplate</p> <p>Default = Varies by model</p>
P0305*	<p>Rated Motor Current</p> <p>0A to 10,000A.</p> <p>Rated motor current (A) from motor nameplate.</p>	<ol style="list-style-type: none"> 1. Press  to advance to parameter P0305. 2. Press  to access the parameter values level. 3. Press  to advance to nominal current. 4. Press  to confirm and save the setting. 	<p>Setting = Motor nameplate</p> <p>Default = Varies by model</p>
P0307*	<p>Rated Motor Power</p> <p>0 kW or hp to 200 kW or hp.</p> <p>Rated motor power (kW or hp) from motor nameplate.</p> <p>If P0100 =1 (60 Hz, hp, North America), then motor power is in hp.</p>	<ol style="list-style-type: none"> 1. Press  to advance to parameter P0307. 2. Press  to access the parameter values level. 3. Press  to advance to nominal power. 4. Press  to confirm and save the setting. 	<p>Setting = Motor nameplate</p> <p>Default = Varies (hp/voltage dependent)</p>











* Motor related parameters.

Parameter	Description	Action	Setting/Default
P0308*, or P0309	<p>Rated Motor cosPhi (P308), or Rated Motor Efficiency (P0309)</p> <p>0.000 to 1.00 (P0308) or 0.0 to 99.9 (P0309)</p> <p>Rated motor cosPhi or motor efficiency from motor nameplate.</p> <p>If P0100 = 2 and P0307 = kW, P0308 displays; If P0100 = 1 and P0307 = hp, P0309 displays.</p> <p>P0309 = 100% corresponds to super conducting.</p> <p>NOTE: This parameter is available when P0003 = 3 and P0010 = 1.</p>	<ol style="list-style-type: none"> 1. Press  to advance to parameter P0308 or 0309. 2. Press  to access the parameter values level. 3. Press  to advance to nominal cosPhi or motor efficiency. 4. Press  to confirm and save the setting. 	<p>Setting = Motor nameplate</p> <p>P0308 Default = 0.00</p> <p>P0309 Default = Varies (hp/voltage dependent)</p>
P0310*	<p>Rated Motor Frequency</p> <p>12 Hz to 650 Hz</p> <p>Rated motor frequency (Hz) from motor nameplate.</p> <p>Pole pair number is recalculated automatically if the parameter is changed.</p>	<ol style="list-style-type: none"> 1. Press  to advance to parameter P0310. 2. Press  to access the parameter values level. 3. Press  to advance to nominal frequency (60 Hz). 4. Press  to confirm and save the setting. 	<p>Setting = Motor nameplate 60 Hz</p> <p>Default = 50 Hz/ 60 Hz</p> <p>Default is dependent on the setting of the motor frequency and unit of measurement DIP switches.</p>











* Motor related parameters.

Parameter	Description	Action	Setting/Default
P0311*	<p>Rated Motor Speed 0 to 40,000 1/min</p> <p>Rated motor speed (rpm) from motor nameplate.</p> <p>A setting of 0 causes an internal calculation of this value.</p> <p>Vector control and V/f control with speed controller require this value.</p> <p>Slip compensation in V/f control requires this value for correct operation.</p> <p>Pole pair number is recalculated automatically if the parameter is changed.</p>	<ol style="list-style-type: none"> 1. Press  to advance to parameter P0311. 2. Press  to access the parameter values level. 3. Press  to advance to nominal motor speed. 4. Press  to confirm and save the setting. 	<p>Setting = Motor nameplate</p> <p>Default = Varies by model</p>
P0640	<p>Motor Overload Factor 10% to 400%</p> <p>Limited to the maximum SED2 output current rating, or to 400% of the rated current (P0305), whichever is lower.</p> <p>NOTE: This parameter is available when P0003 = 3 and P0010 = 1</p>	<ol style="list-style-type: none"> 1. Press  to advance to parameter P0640. 2. Press  to access the parameter values level. 3. Press  to advance to desired value. 4. Press  to confirm and save the setting. 	<p>Setting = As applicable</p> <p>Default = 110</p>

















* Motor related parameters.





Parameter	Description	Action	Setting/Default
P0700(0)**	<p>Selection of Command Source (Start Command)</p> <p>Selects the command source as follows:</p> <p>0 = Factory default setting</p> <p>1 = BOP (keypad)</p> <p>2 = Terminal digital input</p> <p>4 = USS on BOP link (AOP)</p> <p>5 = USS on COM link</p> <p>6 = CB (Communications board or module) on COM link (P1/N2)</p>	<ol style="list-style-type: none"> 1. Press  to advance to parameter P0700. 2. Press  to access the parameter indexes. 3. Press  to advance to index [0], IN000, AUTO. 4. Press  to confirm index selection. 5. Press  to advance to 2. 6. Press  to confirm and save the setting. 	<p>Setting = 2</p> <p>Default = 2</p>
<p>NOTE: Changing this parameter resets (to default) all settings on the selected item. For example, changing from 1 to 2 resets all digital inputs to default settings.</p>			
P0700[1]**	<p>Selection of Command Source (Start Command)</p> <p>Selects the command source as follows:</p> <p>0 = Factory default setting</p> <p>1 = BOP (keypad)</p> <p>2 = Terminal digital input</p> <p>4 = USS on BOP link (AOP)</p> <p>5 = USS on COM link</p> <p>6 = CB (Communications board or module) on COM link (P1/N2)</p>	<ol style="list-style-type: none"> 1. Press  to advance to index [1], IN001, HAND. 2. Press  to confirm index selection. 3. Press  to advance to 1. 4. Press  to confirm and save the setting. 5. Press  again to return to the parameter selection level. 	<p>Setting = 1</p> <p>Default = 1</p>
<p>NOTE: Changing this parameter resets (to default) all settings on the selected item. For example, changing from 1 to 2 resets all digital inputs to default settings.</p>			

** Parameters have two index settings: IN000 = Auto and IN001 = Hand.

Parameter	Description	Action	Setting/Default
P1000[0]**	<p>Selection of Frequency Setpoint (Speed Command Source)</p> <p>Selects the frequency setpoint source as follows:</p> <p>1 = Motor potentiometer setpoint/BOP (keypad)</p> <p>2 = Analog input</p> <p>3 = Fixed frequency setpoint</p> <p>4 = USS on BOP Link/AOP</p> <p>5 = USS on COM link</p> <p>6 = CB (Communications board or module) on COM link/P1-N2 communications</p>	<ol style="list-style-type: none"> 1. Press  to advance to parameter P1000. 2. Press  to access the parameter indexes. 3. Press  to advance to index [0], IN000, AUTO. 4. Press  to confirm index selection. 5. Press  to advance to 2. 6. Press  to confirm and save the setting. 	<p>Setting = 2</p> <p>Default = 2</p>
P1000[1]**	<p>Selection of Frequency Setpoint (Speed Command Source)</p> <p>Selects the frequency setpoint source as follows:</p> <p>1 = Motor potentiometer setpoint/AOP</p> <p>2 = Analog input</p> <p>3 = Fixed frequency</p> <p>4 = USS on BOP Link/AOP</p> <p>5 = USS on COM link</p> <p>6 = CB (Communications board or module) on COM link/P1-N2 communications</p>	<ol style="list-style-type: none"> 1. Press  to advance to index [1], IN001, HAND. 2. Press  to confirm index selection. 3. Press  to advance to 1. 4. Press  to confirm and save the setting. 5. Press  again to return to the parameter selection level. 	<p>Setting = 1</p> <p>Default = 1</p>

** Parameters have two index settings: IN000=Auto and IN001=Hand.

Parameter	Description	Action	Setting/Default
P1080	<p>Minimum Motor Frequency</p> <p>0 Hz to 650 Hz</p> <p>Minimum motor frequency at which the motor will run irrespective of the frequency setpoint. This value applies to both clockwise and counterclockwise rotation.</p>	<ol style="list-style-type: none"> 1. Press  to advance to parameter P1080. 2. Press  to access the parameter values level. 3. Press  to advance to desired value. 4. Press  to confirm and save the setting. 	<p>Site Setting (20% to 30% Max)</p> <p>Default = 10</p>
P1082	<p>Maximum Motor Frequency</p> <p>0 Hz to 650 Hz</p> <p>Maximum motor frequency at which the motor will run regardless of the frequency setpoint. This value applies to both clockwise and counterclockwise rotation.</p>	<ol style="list-style-type: none"> 1. Press  to advance to parameter P1080. 2. Press  to access the parameter values level. 3. Press  to advance it desired value. 4. Press  to confirm and save the setting. 	<p>Site Setting Default = 50 or 60</p> <p>(Default is determined by the setting of the motor frequency and unit of measurement DIPswitches.)</p>
<p>NOTE:</p> <p>This value is limited internally to 200 Hz or five times the rated motor frequency (P0305) When P1300 is greater than or equal to 20 (control mode = vector control). The value displays via r0209 (maximum frequency.</p>			
P1120	<p>Ramp-up Time</p> <p>0s to 650s</p>	<ol style="list-style-type: none"> 1. Press  to advance to parameter P1120. 2. Press  to access the parameter values level. 3. Press  to advance it desired value. 4. Press  to confirm and save the setting. 	<p>Site Setting</p> <p>Default = 10</p> <p>Typical fan = 120s</p> <p>Typical pump = 30s</p>
<p>NOTES:</p> <ol style="list-style-type: none"> 1. Setting the ramp-up time too short can cause the SED2 to trip (F0001 over current, F0002 over voltage, or F0003 under voltage.) 2. If using an external frequency setpoint with set ramp rates (such as from a PLC), achieve optimum SED2 performance by setting ramp time (P1120 and P1121) slightly shorter than those of the PLC. 			
P1121	<p>Ramp-down time</p> <p>0s to 650s</p>	<ol style="list-style-type: none"> 1. Press  to advance to parameter P1121. 2. Press  to access the parameter values level. 3. Press  to advance it desired value. 4. Press  to confirm and save the setting. 	<p>Site Setting</p> <p>Default = 30</p> <p>Typical fan = 120s</p> <p>Typical pump = 30s</p>
<p>NOTES:</p> <ol style="list-style-type: none"> 1. Setting the ramp-up time too short can cause the SED2 to trip (F0001 over current, F0002 over voltage, or F0003 under voltage. 2. If using an external frequency setpoint with set ramp rates (such as from a PLC), achieve optimum SED2 performance by setting ramp times (P1120 and P1121) slightly shorter than those of the PLC. 			

Parameter	Description	Action	Setting/Default
P3900	<p>End Quick Commissioning</p> <p>0 = End without motor calculation or factory reset.</p> <p>1 = End with motor calculation and factory reset (recommended on SED2 <i>without</i> bypass option).</p> <p>2 = End with motor calculation and with I/O reset.</p> <p>3 = End with motor calculation but without I/O reset (recommended with SED2 <i>with</i> bypass option).</p>	<p>1. Press  to advance to parameter P3900.</p> <p>2. Press  to access the parameter values level.</p> <p>3. Press  to advance to 1.</p> <p>4. Press  to confirm the setting.</p>	<p>Setting = 1</p> <p>Default = 0</p>
<p>NOTES:</p> <p>1. P0010 <i>must always</i> be set back to 0 before operating the motor.</p> <p>2. If P3900 is less than 0 on completion of commissioning, P0010 is automatically set back to 0.</p> <p>3. If P0700 either indeed was changed during this process, programming of P0704 = 3 is required.</p>			

Required SED2 Parameter Settings

The factory programs the following SED2 parameters before shipping. If these parameters are changed or if the SED2 is ever reset to factory default, you must reset these parameters as follows:

Parameter	Setting
P0748	----
P0704 in000	3
P0704 in001	3
P0731	52.3

NOTES:

1. The SED2 Fault must always be programmed as a fault. Do not change the SED2 fault relay for other uses via P0731.
2. Changing P0700 resets all digital inputs and P0704 will require programming.

Technical Specifications

Table 5. Conventional Bypass Specifications.

Specifications	Description
Input Voltage (3 phase)	208V, 3AC ± 10%
	230V, 3AC ± 10%
	460V, 3AC ± 10%
	575V, 3 AC ± 10%
Temperature	Operating: 14°F to 104°F (-10°C to 40°C)
	Storage: -40°F to 158°F (-40°C to 70°C)
Humidity	0 to 95% rh, non-condensing

NOTE: For technical specifications on the SED2, see the *SED2 VFD Startup, Operation and Maintenance Manual*, (125-3201).

Table 6. Drive Specifications

Drive Specifications	Description
Input voltage and power ranges (3 phase) Amps	200V to 240V, 3 AC \pm 10%. 1/2 hp to 60 hp (2.3 Amps to 154 Amps)
	380V to 480V, 3 AC \pm 10% 1/2 hp to 125 hp (1.2 Amps to 178 Amps)
	500V to 600V, 3 AC \pm 10% 1 hp to 125 hp (2.3 Amps to 125 Amps)
Input frequency	47 Hz to 63 Hz
Output frequency	0 Hz to 150 Hz
Power factor	\geq 0.9
VFD degree of efficiency	96% to 97%
Switch-on current	Less than nominal input current
Auxiliary supply 24V	Galvanically separated, unregulated auxiliary supply (18V to 32V) 100 mA
Overload capacity	110% for 60 seconds, 150% for 3 seconds
Control method	Linear, parabolic and programmable V/f; and flux current control low-power mode
PWM frequency	2k Hz to 16k Hz (adjustable in 2k Hz increments)
Fixed frequencies	15 programmable
Skip frequency bands	4 programmable
Setpoint resolution	0.01 Hz digital
	0.01 Hz serial
	10 bit analog
Digital inputs (sink/source)	6: fully programmable and scalable isolated digital inputs, switchable
Analog inputs	2: 0 to 10 Vdc, 0/4 mA to 20 mA , can also be configured as digital inputs or Ni 1000 input
Relay outputs	2: configurable 30 Vdc/5A (resistive), 250 Vac 2A (inductive)
Analog outputs	2: programmable (0/4 mA to 20 mA or 0V to 10 Vdc)
Serial interface	RS-485; Protocols: Siemens, P1 and Johnson, N2; Transmission rate: Up to 38.4k Baud
Protection level	IP20: NEMA Type 1 (with protective shield and gland plate installed)
	IP54: NEMA Type 12 (400V and 500V series only)
Temperature ranges	Operating: 14°F to 104°F (–10°C to 40°C)
	Storage: –40°F to 158°F (–40°C to 70°C)
Humidity	95% rh, non-condensing
Operational altitudes	Up to 3280 ft (1000 m) above sea level without de-rating
Protection features	<ul style="list-style-type: none"> • Under-voltage • Over-voltage • Overload • Ground fault • Short circuit • Stall prevention • Locked motor • Motor over temperature I²t, PTC • Over-temperature • Parameter PIN protection
Standards	UL, cUL
CE conformity	Conformity with EC Low Voltage Directive 73/23/EEC

Wiring Diagrams

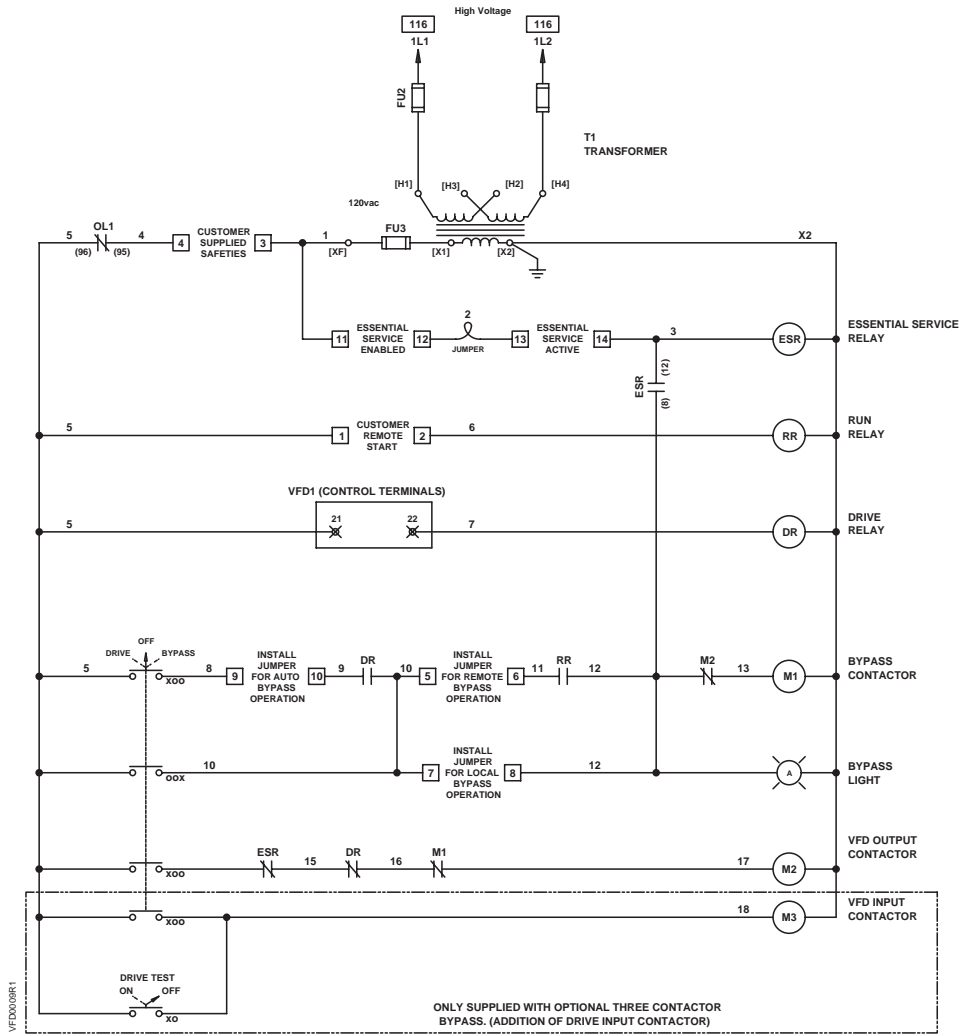
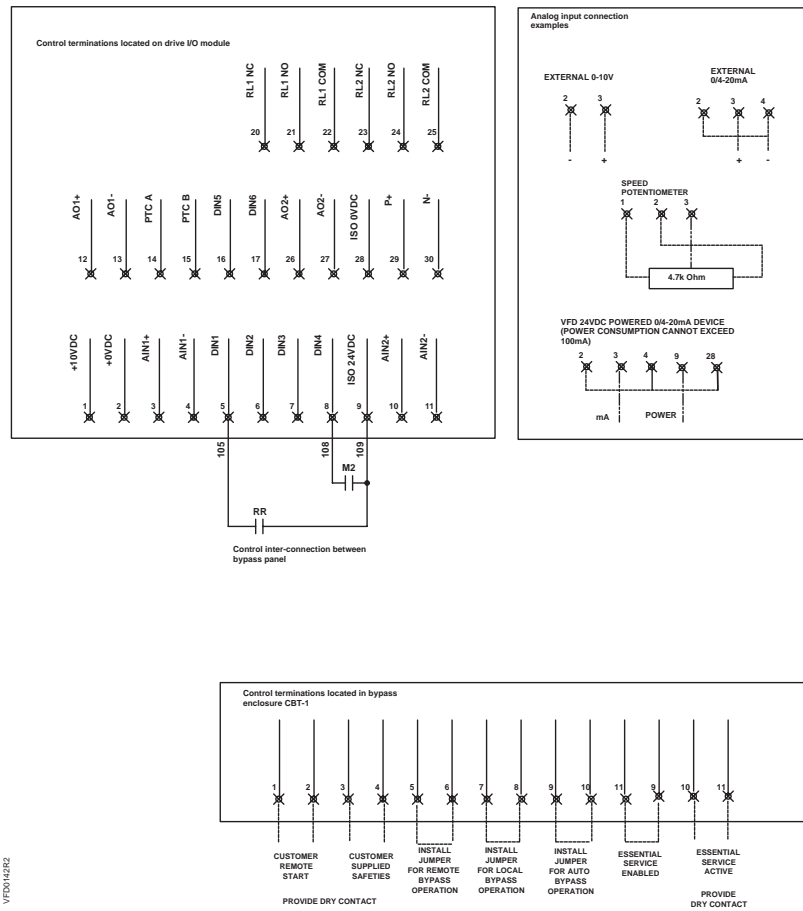

Figure 14. Bypass 120 Vac Control Circuit.

Control Terminals



VFD014232

Note: Jumpers are factory supplied.

Figure 15. Terminations.

Troubleshooting

Description of Problem	Possible Cause
Commanding the SED2 to start closes the bypass contactor.	SED2 required programming for bypass operation has not been programmed in the VFD. Make appropriate VFD programming changes. See <i>Required SED2 Parameter Setting</i> .
Contactors do not close.	<ul style="list-style-type: none"> • Main input short circuit protection has opened. • Control power fuse has opened. • Safety circuit is open. • Motor overload needs to be reset. • Loose control wire connection.
Drive does not start on closing of bypass control terminals 1 and 2.	<ul style="list-style-type: none"> • Drive–Off–Bypass switch is not in the Drive position. • Drive output contactor is not closed. • Remote contact is not really closing, replace with a wire jumper or use drive parameters to verify this contact closure. • Run relay has failed. • Loose control wire connection. • Drives digital input 1 is not programmed appropriately.
Main input fuses clear when motor is run in bypass	<p>The short circuit protection supplied by the factory is approximately 1.5 times NEC listed motor current rating.</p> <p>Some applications and motor characteristics may require up sizing this protection. If this is required in the field, ensure that there is an appropriate match between the fuses type and rating with fuse holder.</p>

Fuses

Verify that 120 Vac power is available on the secondary side of the Conventional Bypass Option power transformer. If power is not proper, check the Conventional Bypass Option components, such as:

- Power transformer
- Power transformer fuses (F1, F2, and F3). Table 7 provides fuse replacement information.

Table 7. Fuse Replacement Information.

Bypass Option Part Number	Primary Fuse (F1 and F2)	Secondary Fuse (F3)
VBA10.5... to VBA17.5...	Bussmann/Littlefuse LP-CC-1	Bussmann/Littlefuse LP-CC-6/10
VBA110... to VBA110...	Bussmann/Littlefuse LP-CC-2	Bussmann/Littlefuse LP-CC-1 1/4
VBA115... to VBA160...	Bussmann/Littlefuse LP-CC-3	Bussmann/Littlefuse LP-CC-2
VBA20.5... to VBA27.5...	Bussmann/Littlefuse LP-CC-1	Bussmann/Littlefuse LP-CC-6/10
VBA210... to VBA210...	Bussmann/Littlefuse LP-CC-2	Bussmann/Littlefuse LP-CC-1 1/4
VBA215... to VBA260...	Bussmann/Littlefuse LP-CC-3	Bussmann/Littlefuse LP-CC-2
VBA30... to VBA315...	Bussmann/Littlefuse LP-CC-1/2	Bussmann/Littlefuse LP-CC-6/10
VBA320... to VBA320...	Bussmann/Littlefuse LP-CC-1	Bussmann/Littlefuse LP-CC-1 1/4
VBA325... to VBA3125...	Bussmann/Littlefuse LP-CC-1 1/2	Bussmann/Littlefuse LP-CC-2
VBA40... to VBA420...	Bussmann/Littlefuse FNQ-R-4/10	Bussmann/Littlefuse LP-CC-6/10
VBA425... to VBA425...	Bussmann/Littlefuse LP-CC-8/10	Bussmann/Littlefuse LP-CC-1 1/4
VBA430... to VBA4125...	Bussmann/Littlefuse LP-CC-1 1/4	Bussmann/Littlefuse LP-CC-2

Siemens Building Technologies, Inc.

1000 Deerfield Parkway
Buffalo Grove, IL 60089-4513
Tel: +1 847-215-1000
Fax +1 847-215-1093

Siemens Building Technologies, Ltd.

2 Kenview Blvd.
Brampton, Ontario
Canada L6T 5E4
Tel: +1 905-799-9937

www.sbt.siemens.com